

CS4+

Control panel of the top device featuring four toggle switches labeled 'OFF', a central vertical slider, and four ports. The leftmost port is labeled '4' and 'E-Data'.

Control panel of the second device from the top, featuring five toggle switches labeled 'OFF', a central vertical slider, and five ports labeled '1' through '5'. A 'DMT' logo is on the left.

Control panel of the bottom device, featuring four toggle switches labeled 'OFF', a central vertical slider, and four ports labeled '1' through '4'. A 'DMT' logo is on the left.

TRADEMARKS

Danish Myo Technology A/S reserves the right to alter specifications as required. This document was, as far as possible, accurate at the time of production. Changes may have been made to the software and hardware it describes since then. New information may be supplied separately. No part of this document may be reproduced by any means without the prior written permission of Danish Myo Technology A/S.

Copyright ©Danish Myo Technology A/S

Warning: Stimulator is not approved for use on Human subjects.

Caution: Risk of Electric shock.

Safe operating Procedures and proper use of the equipment are the user's responsibility.

Danish Myo Technology A/S provides information on how to use this stimulator, but Danish Myo Technology A/S is not responsible for the after-sale operation and safety practices. This is a matter for the user when working with the stimulator.

All personnel who work with or are exposed to this equipment must take precautions to protect themselves against possible serious injury.

Do not remove the input or output cables whilst the stimulator is active (Output switch ON). Never short-circuit the high voltage output of the stimulator. It can result in potential risk of electric shock to the user, and damage the system.

Pulsed Power systems are capable of random triggering via transients or ESD. Therefore, when the stimulator output switch is turned ON, assume it's possible to get a pulse on the output connector.

CONTENTS

TRADEMARKS	3
WARNING	6
CHAPTER 1 - SYSTEM OVERVIEW	7
1.1 CS4/CS4+ Stimulator: Front Panel	7
1.2 CS8 Stimulator: Front Panel	7
1.3 CS4 Stimulator: Rear Panel	8
1.4 CS8 Stimulator: Rear Panel	8
CHAPTER 2 - SETTING UP	10
2.1 Getting started	10
CHAPTER 3 - FUNCTIONS AND INTERFACE	11
3.1 Definitions within the MyoPULSE	11
3.2 MyoPULSE Software	13
3.3 MyoPULSE Configuration	21
3.4 Stimulation Protocol Guide	25
3.4 Stimulation Protocol Guide	25
CHAPTER 4 - EXPERIMENTAL SETUP	55
4.1 Starting a Stimulation Protocol	55
4.2 Saving a Stimulation Protocol	61
4.3 Input Trigger	64
APPENDIX A	67
System CS4/CS8 Specifications	67
System CS4+ Specifications	67
APPENDIX B	68

APPENDIX C

71

Trigger Input

71

APPENDIX D

72

WARNING

THIS STIMULATOR IS NOT APPROVED FOR USE ON HUMAN SUBJECTS.

CAUTION: RISK OF ELECTRIC SHOCK.

SAFE OPERATING PROCEDURES AND PROPER USE OF THE EQUIPMENT ARE THE USER'S RESPONSIBILITY.

Danish Myo Technology A/S provides information on how to use this stimulator, but Danish Myo Technology A/S is not responsible for the after-sale operation and safety practices. This is a matter for the user when working with the stimulator.

ALL PERSONNEL WHO WORK WITH OR ARE EXPOSED TO THIS
MUST TAKE PRECAUTIONS TO PROTECT THEM SELVES AGAINST POSSIBLE SERIOUS INJURY.

1. Do not remove the input or output cables while the stimulator is active (output switch ON). Never short-circuit the high voltage output of the stimulator. It can result in potential risk of electric shock to the user, and damage the system.
2. Pulsed power systems are capable of random triggering via transients or ESD. Therefore when the stimulator output switch is turned ON, assume it is possible to get a pulse on the output connector.

Unpacking the Stimulator

Package contents of the Stimulator

On unpacking the Stimulator,

1. The Stimulator, power supply and data acquisition USB cable are packaged separately and need to be connected into the stimulator as a complete working instrument. Connect the power supply to the CS4/CS8 stimulator, the USB cable is used to connect the CS4/CS8 stimulator to the computer with the installed MyoPULSE software.
2. The stimulator is present as a single unit as depicted in 1.1 and the rear panel as depicted in 1.3 for the CS4 stimulator respectively.

CHAPTER 1 - SYSTEM OVERVIEW

1.1 CS4/CS4+ STIMULATOR: FRONT PANEL



Figure 1.1 Stimulator CS4 and CS4+ front panel

CS4 Stimulator
Cable connector

1.2 CS8 STIMULATOR: FRONT PANEL



Figure 1.2 Stimulator CS8 front panel

CS8 Stimulator Cable

1.3 CS4 STIMULATOR: REAR PANEL

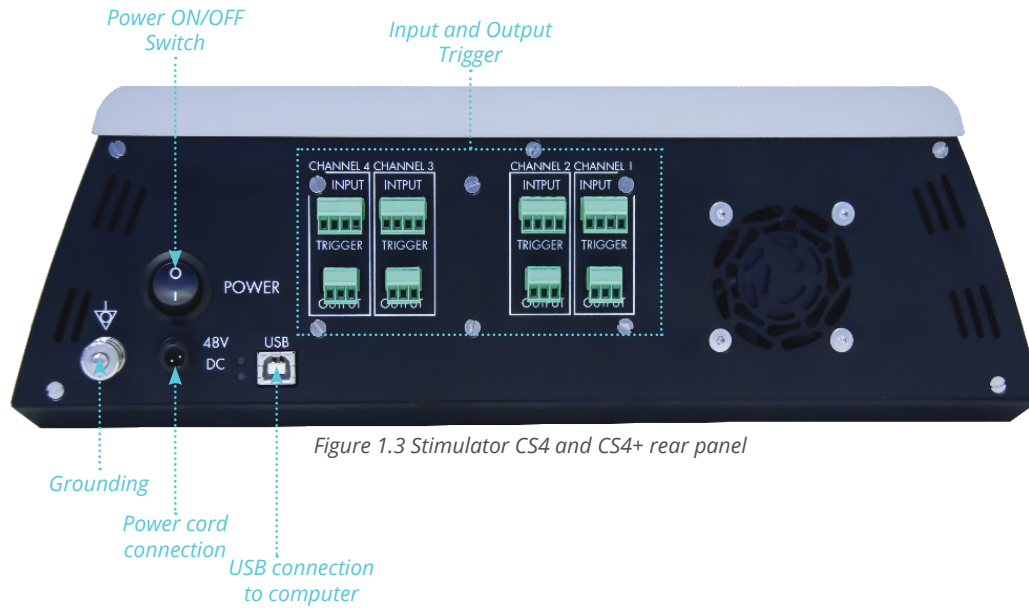

1.4 CS8 STIMULATOR: REAR PANEL

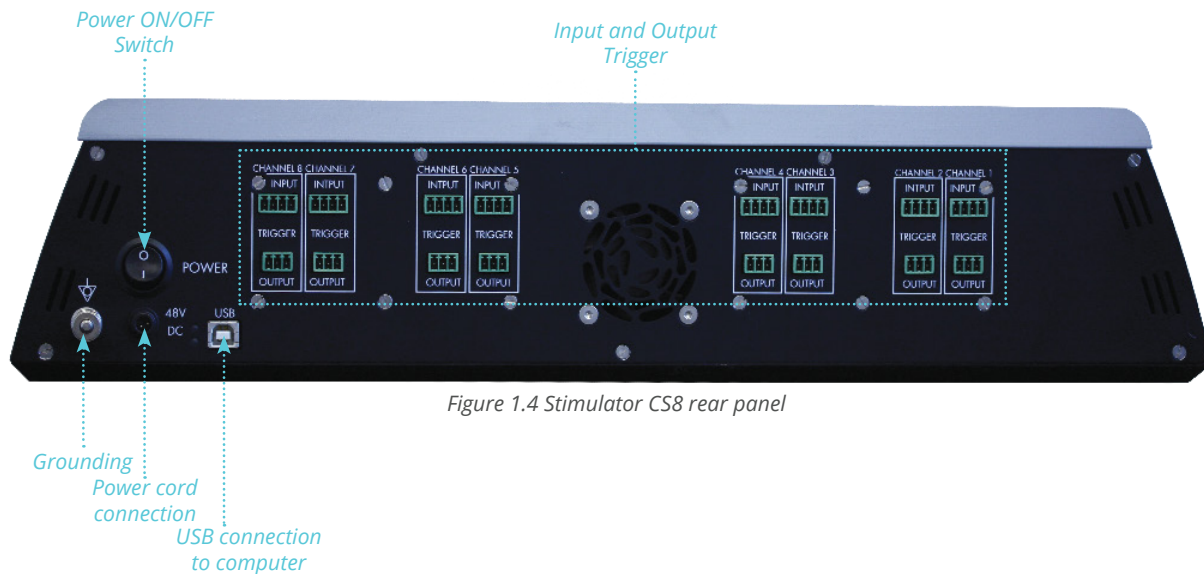

Users of the DMT 840MD MyoDYNAMICS Muscle strip myograph and a CS4/CS4+/CS8 stimulator will get Trigger Cables (figure 1.5) with their orders. The Trigger cable will connect the 840MD Trigger ports with the CS4, CS4+ or CS8 Trigger IN/OUT ports making it possible for the 840MD to trigger a stimulation protocol or for the CS4/CS4+/CS8 to trigger the motors on the 840MD chamber to start.

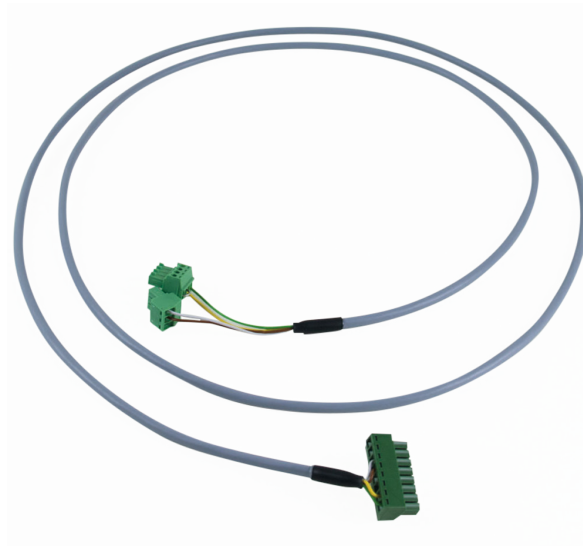

Figure 1.5 Trigger Cable connecting CS4/CS4+/CS8 and 840MD system

CHAPTER 2 - SETTING UP

2.1 GETTING STARTED

The following steps involve getting started with the stimulator.

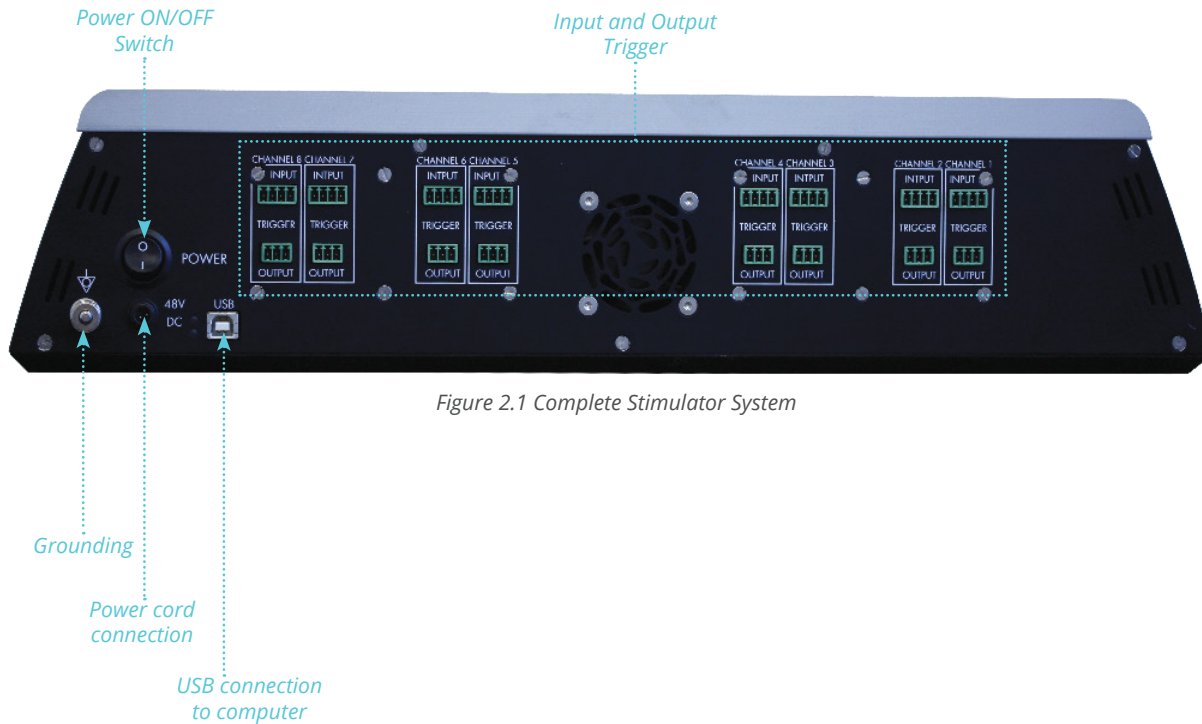

Figure 2.1 Complete Stimulator System

- Connect the supplied 48volt power converter to the Stimulator Power cord plug and click Power Switch 'ON' on the rear Panel.
- Connect the Stimulator to the computer with the supplied USB cable.
- Follow the supplied Quick Installation Guide for the MyoPULSE stimulator software (Appendix A).
- Start the MyoPULSE Software on the computer.
- Optional: Users of 840MD MyoDYNAMICS myographs connect it to the CS4/CS4+/CS8 stimulator using the supplied Trigger cables.

CHAPTER 3 - FUNCTIONS AND INTERFACE

3.1 DEFINITIONS WITHIN THE MYOPULSE

The CS4, CS4+ or the CS8 Stimulator can only be operated using the MyoPULSE Software. The function of the MyoPULSE Software is to set all the pulse parameters and upload this to the CS4, CS4+ and CS8 Stimulators.

Here below the different terms used in this manual are shown (figure 3.1.1 - 3.1.3).

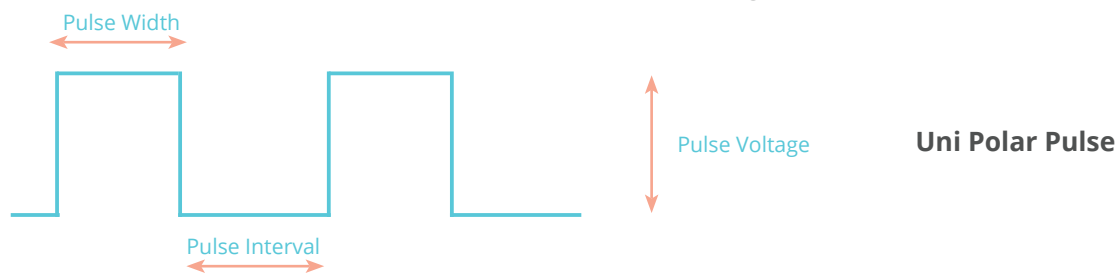

Figure 3.1.1

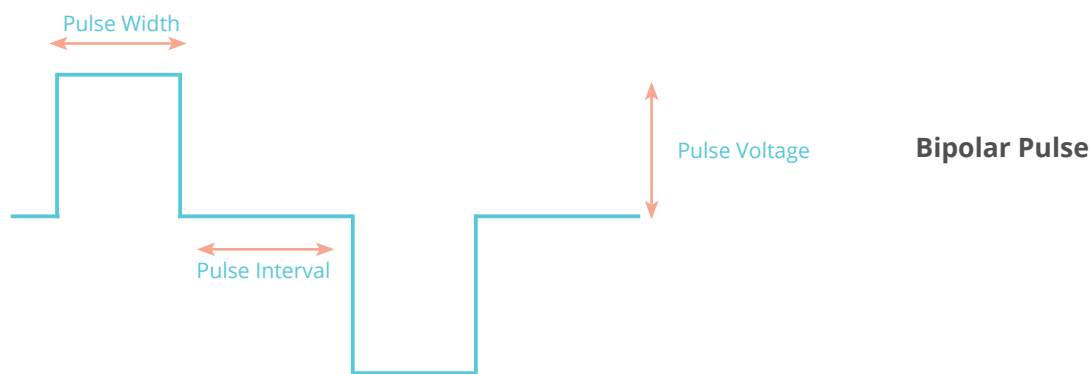

Figure 3.1.2

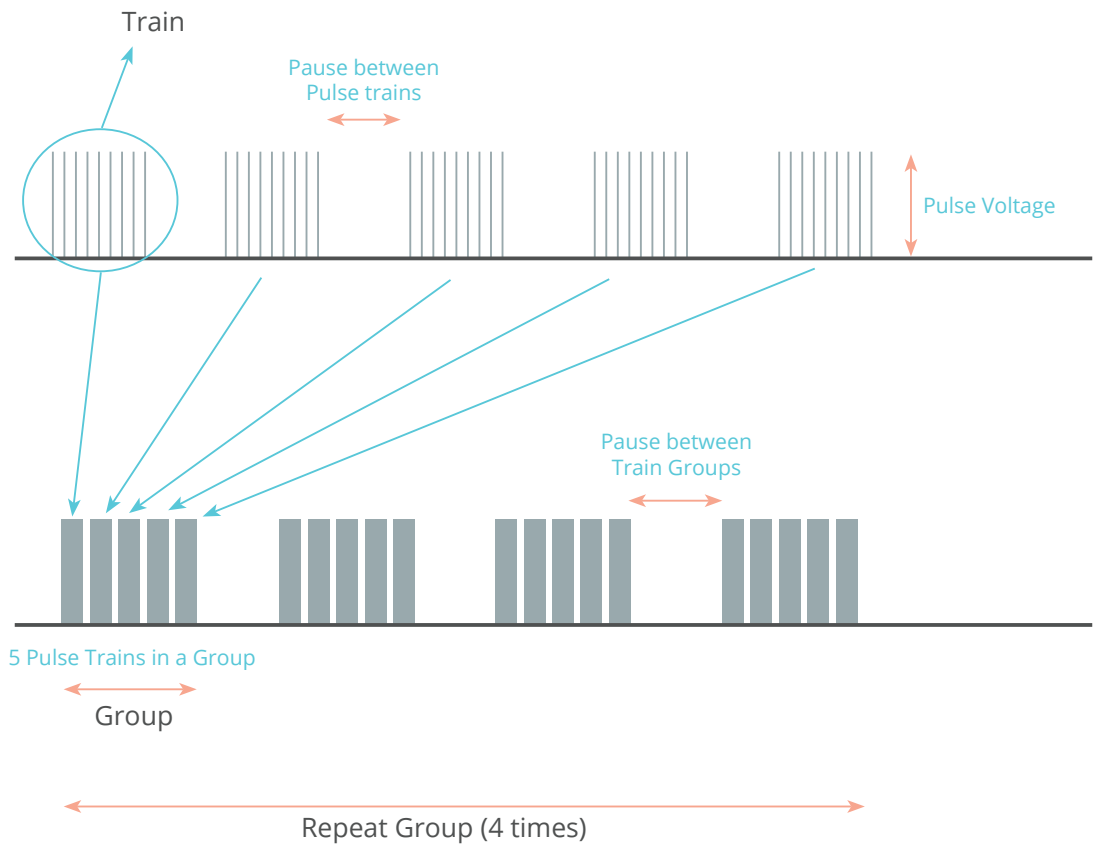

Figure 3.1.3

3.2 MYOPULSE SOFTWARE

There is a single main interface available for the CS4, CS4+ or CS8 Stimulator the MyoPULSE software.

3.2.1 MYOPULSE SOFTWARE INSTALLATION

Install the MyoPULSE software as described in Appendix A.

After the MyoPULSE installation, the MyoPULSE program is started by clicking on 'Start', then 'All Programs', then 'DMT' and then 'MyoPULSE'.

NOTE: Right click on MyoPULSE software and select "send to" to create a MyoPULSE shortcut on your desktop

3.2.2 MYOPULSE MAIN SCREEN

The following MyoPULSE interface can be viewed on the screen as depicted.

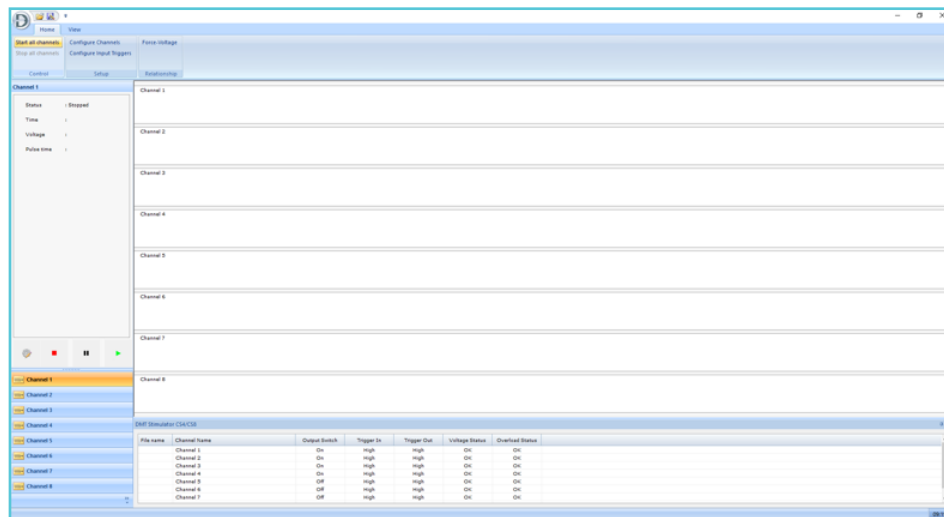

Figure 3.2.1 MyoPULSE start interface

As long as the Stimulator has not been switched 'Off', MyoPULSE will start up with the same stimulation protocol in use from the last time as shown in figure 3.2.2.

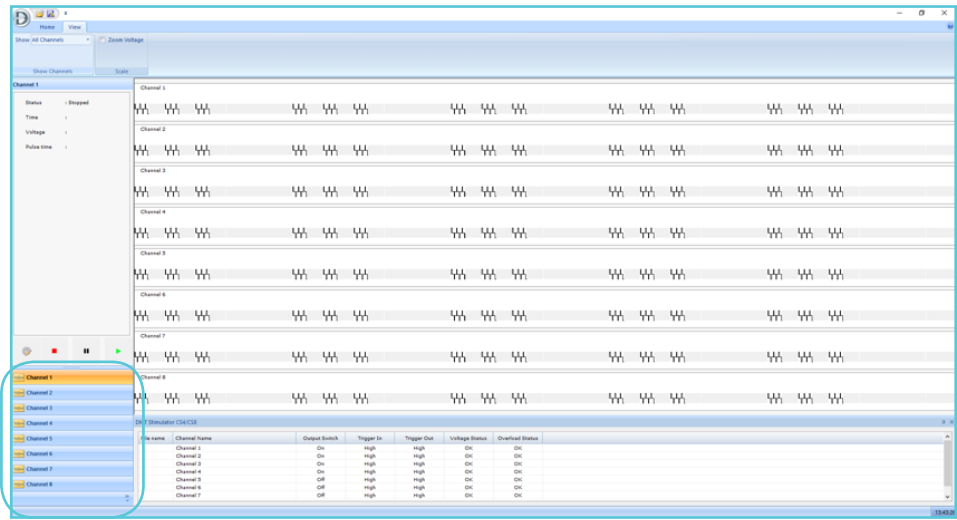

Figure 3.2.2 MyoPULSE channel buttons

The MyoPULSE program is made for the CS4, CS4+ and CS8 stimulator and as in Figure 3.2.2, the Stimulation protocol overview as well as the Channel 1 to Channel 8 (blue box) will be shown even though only a 4-channel CS4 or CS4+ stimulator is connected.

It is possible to reduce the number of channels (blue box in figure 3.2.2) to only channel 1-4 for CS4 and CS4+ users. There is two ways to remove Channel 5-8 in MyoPULSE. Press the arrow icon encircled with a blue box in figure 3.2.3 and the window with the menus Show more buttons, Show Fewer buttons and Navigation Pane Options.

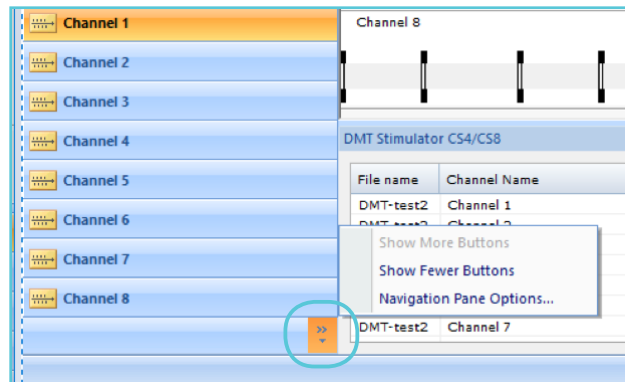

Figure 3.2.3 Changing channel view options

Pressing the Fewer buttons will remove one channel every time this is pressed as shown in Figure 3.2.4 below.

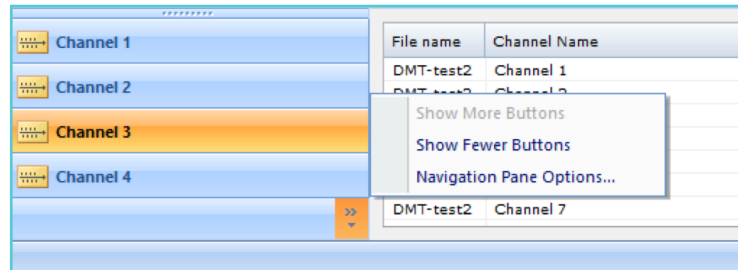

Figure 3.2.4 Reducing the number of channels

The other option to remove channels is to press the Navigation Pane Option. To remove a channel the tick mark is removed for the appropriate channel and press OK as shown in figure 3.2.5 - 3.2.7.

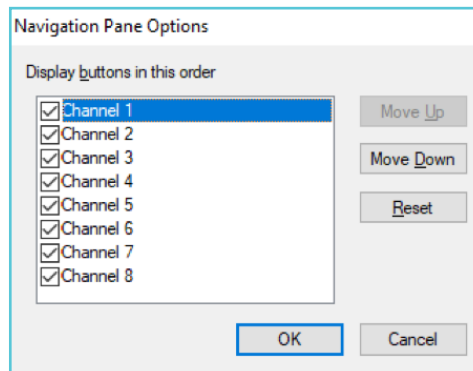

Figure 3.2.5

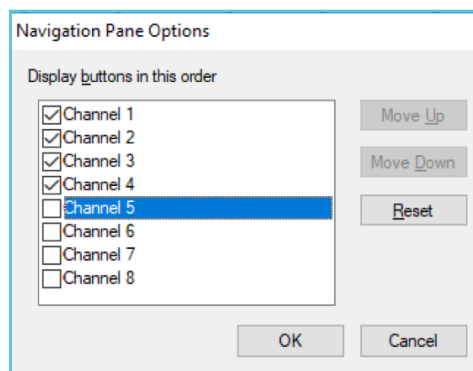

Figure 3.2.6

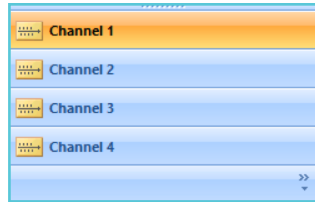

Figure 3.2.7

3.2.3 MYOPULSE MAIN MENUS

In the top left corner (figure 3.2.8), the MyoPULSE main menus can be seen. The main menu includes Home menu and View menu.

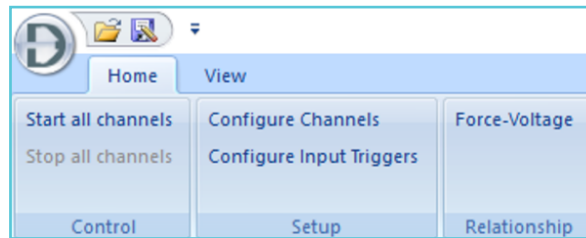

Figure 3.2.8 Home menu

The 'Home' menu, provides the User with their respective sub- menus, 'Control', 'Setup' and 'Relationship' (figure 3.2.8).

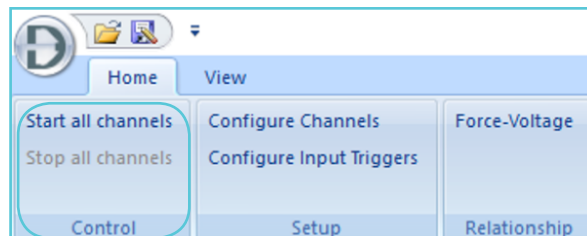

Figure 3.2.9 Control sub menu

The 'Control' sub menu consists of 'Start all channels' and 'Stop all channels' that can be activated by left-clicking as depicted in the blue box.

This sub menu is used to start or stop a user-defined stimulation protocol on the CS4, CS4+ and CS8 stimulator on all channels simultaneously by clicking either Start or Stop.

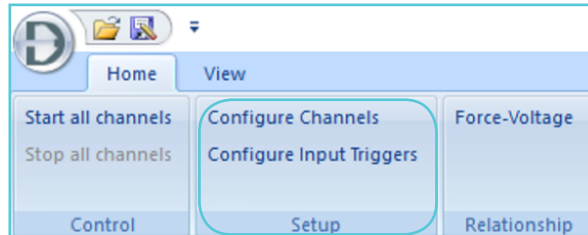

Figure 3.2.10 Setup sub menu

The 'Setup' sub menu (figure 3.2.10) consists of 'Configure Channels' that is used to define a stimulation protocol on all four (CS4 and CS4+) or eight channels (CS8), and 'Configure Input Triggers' that is used to define external Input triggers from a connected systems such as eg. the 840MD MyoDynamics Muscle Strip Myograph System or a Powerlab Data Acquisition system. The external Input Trigger is used to define when a stimulation protocol should start on the CS4, CS4+ or CS8 Stimulator.

NOTE: How to define a stimulation protocol using the 'Configure Channels is described in Chapter 3.3. The configuration of the Input Trigger is described in Chapter 4.3.

The 'Relationship' sub menu consists of 'Force-Voltage' relationship (figure 3.2.11) used to determine the Force-Voltage relationship for the mounted muscle.

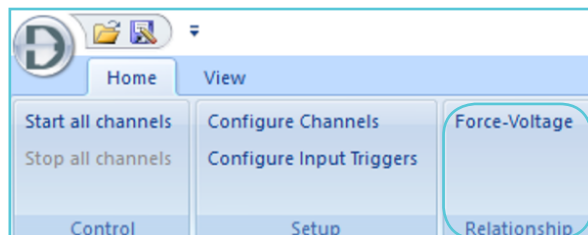

Figure 3.2.11 Relationship sub menu

This is to find the optimum Pulse Voltage needed to be applied to a muscle to produce a maximum muscle contraction. This is done by performing a Single Pulse voltage "Twitch" by increasing the voltage in user-defined increments, in order to determine the voltage corresponding to the maximum contraction of the muscle.

In the Force-Voltage relationship menu the 'Channel', 'Pulse Voltage', 'Pulse Width' and 'Increment Voltage' can be selected and set to an appropriate value. In figure 3.2.12, the values entered are only for an example.

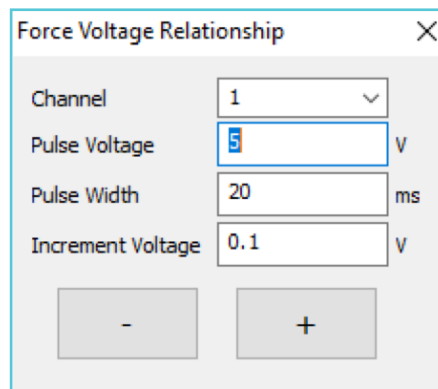

Figure 3.2.12 Force-Voltage Relationship menu

In this example the muscle in Chamber 1 will get a single pulse of 5volt for 20msec when the "+" icon is pressed and next time the "+" icon is pressed the muscle will get a 5.1volt single pulse for 20msec and 5.2volt when then "+" icon is pressed for the third time. By looking at the Force trace in the data acquisition software the user can increase the voltage by pressing the "+" icon until the max force is not increased anymore. The "-" icon will decrease the voltage applied to the muscle by the value entered in the Increment Voltage box.

NOTE: It is important not to enter a too small or too large value in the Increment Voltage. Too small a value will lead to a lot of single stimulus before reaching the max contraction force and you do not want to 'burn out' your muscle for power before the real experiments. Too large a value could mean that you overshoot the voltage for max contraction. Too high voltage will damage the muscle.

The 'View' sub menu (figure 3.2.13) provides the user with two respective sub menus, 'Show channels' and 'Scale'

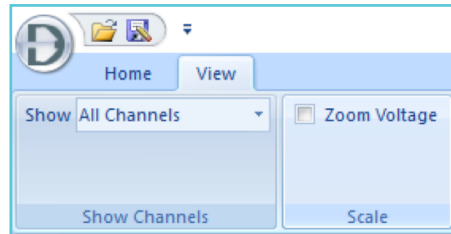

Figure 3.2.13 View menu

The Show Channels submenu comprises of 'All Channels' and 'Started Channels'.

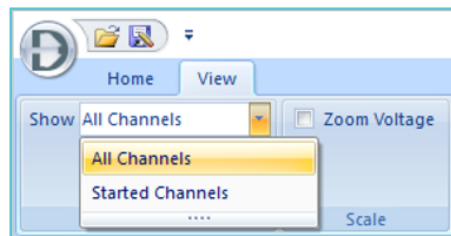

Figure 3.2.14

This is used to determine if the graph view of the stimulation protocol must be displayed for all channels or only the channels where the stimulation protocol is started, respectively.

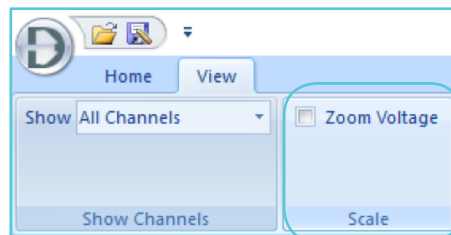

Figure 3.2.15

The Scale submenu contains 'Zoom Voltage' (figure 3.2.15).

Clicking on this will scale the Y-axis in Volts to expand over the whole Y-axis in the graph display of a defined stimulation protocol. After clicking the 'Zoom Voltage', the graph view of the stimulation protocol is scaled to maximum on the Y-axis as depicted in the figure 3.2.16.A-B.

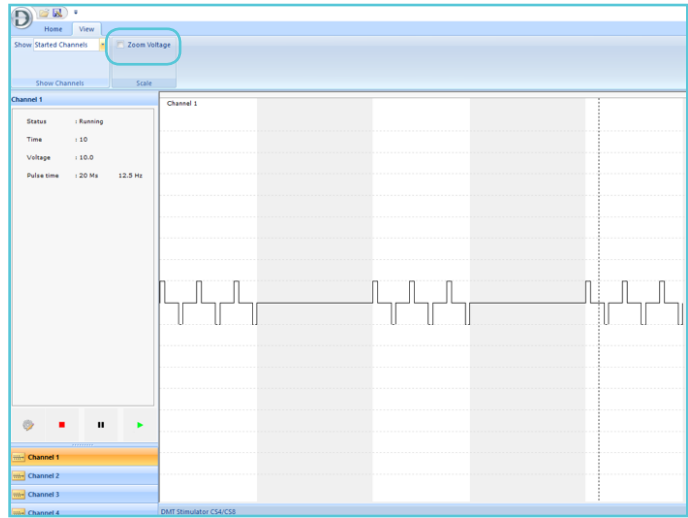

Figure 3.2.16.A Zoom Voltage when de-activated

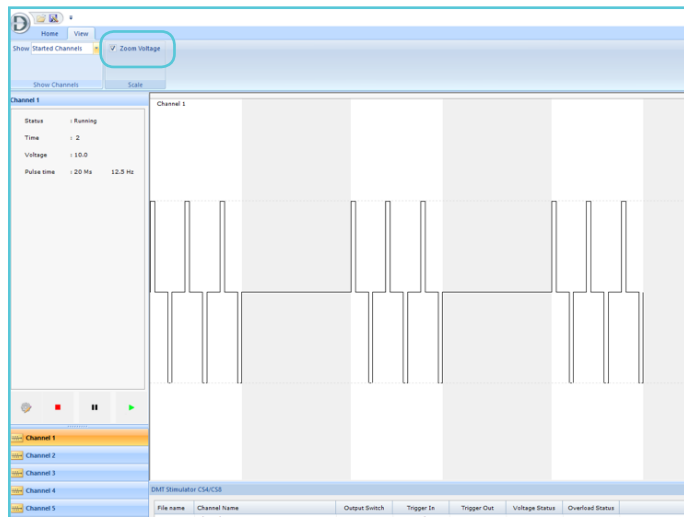

Figure 3.2.16.B Zoom Voltage when activated

3.3 MYOPULSE CONFIGURATION

3.3.1 CONFIGURE CHANNELS - STIMULATION PROTOCOL

In MyoPULSE there are two different ways of configuring the channels and making a stimulation protocol.

1. Configuration of all four/eight channels with the same stimulation protocol.
 - Go to the Home Menu, click on the 'Configure Channels' and the stimulation protocol guide will start up (See chapter 3.4). The protocol will automatically be loaded into all channels of the stimulator when the stimulation protocol guide is finished. After the stimulation protocol, has been made, save the protocol.

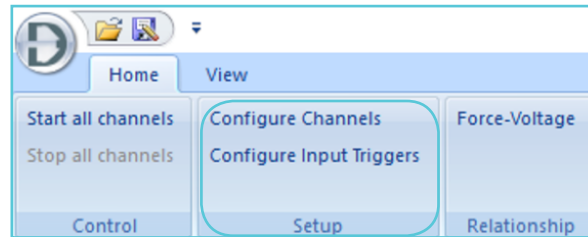

Figure 3.3.1 Configuring All channels

2. Configuration of only a single channel with its specific stimulation protocol.
 - Right click on a given channel, e.g. Channel 3 in the lower left panel of MyoPULSE. The following window will appear on the screen with the following five dropdown menu options (figure 3.3.2):

A) 'Start': Will start the stimulation protocol entered for channel 3.

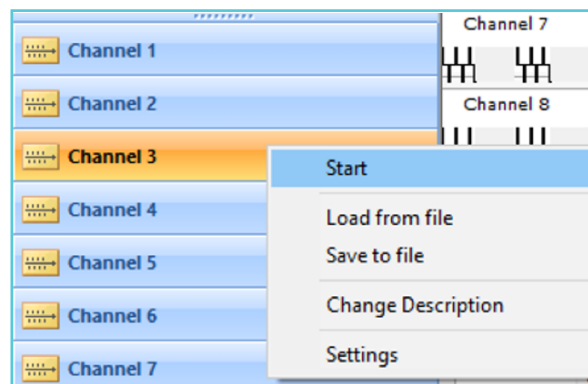

Figure 3.3.2 Configuring a single channel

B) 'Load from file': Will load an existing "single channel stimulation" protocol for that particular channel (figure 3.3.3).

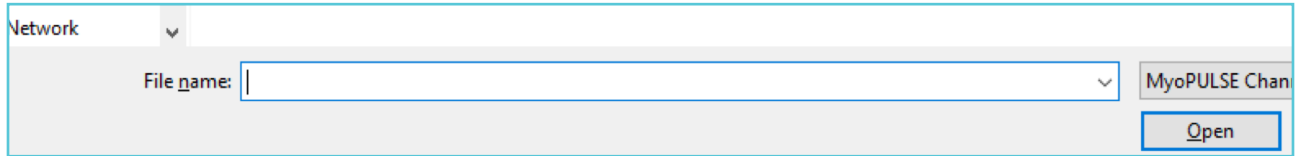

Figure 3.3.3 Load from file option

C) 'Save to file': Will save a single channel stimulation protocol set up to a file (*.plc) that can be loaded into another channel later if needed (figure 3.3.4).

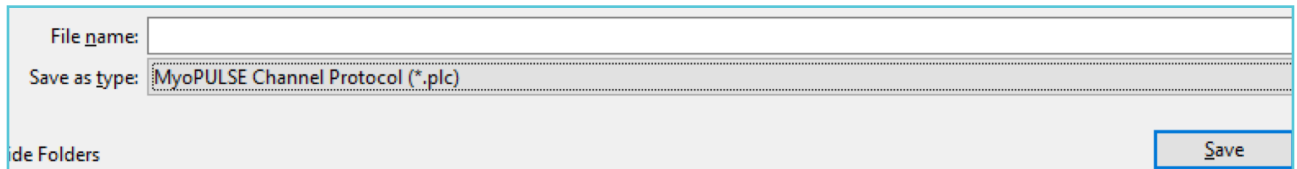

Figure 3.3.4 Save to file option

Below is an example (figure 3.3.5) of a single channel stimulation protocol saved with the name "DMT-Single-Ch". The file name will be shown in the column "File name".

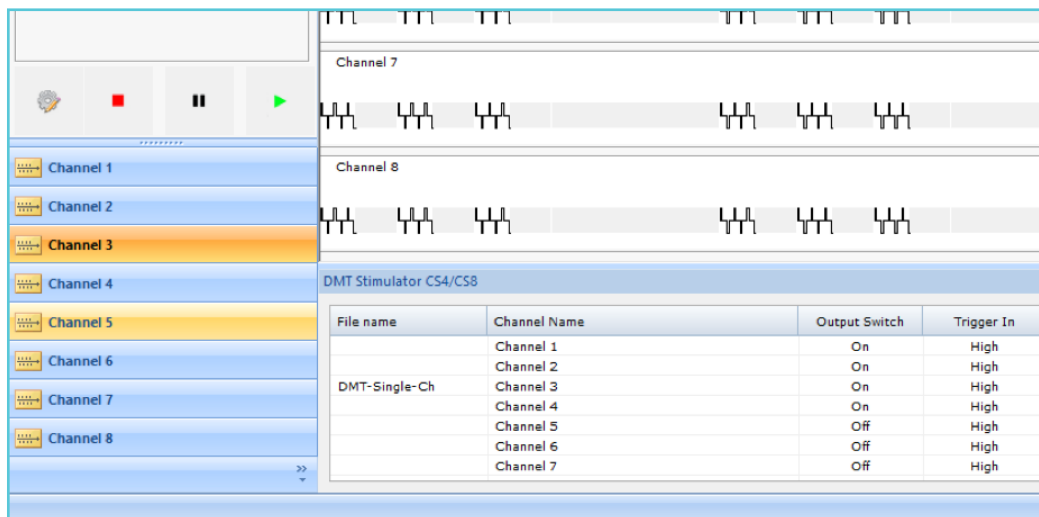

Figure 3.3.5 Loaded stimulation file

The single channel protocol file 'DMT-Single-Ch' with the file extension plc can now be loaded into another channel by selecting 'Load from file'. Here below it is loaded into channel 1.

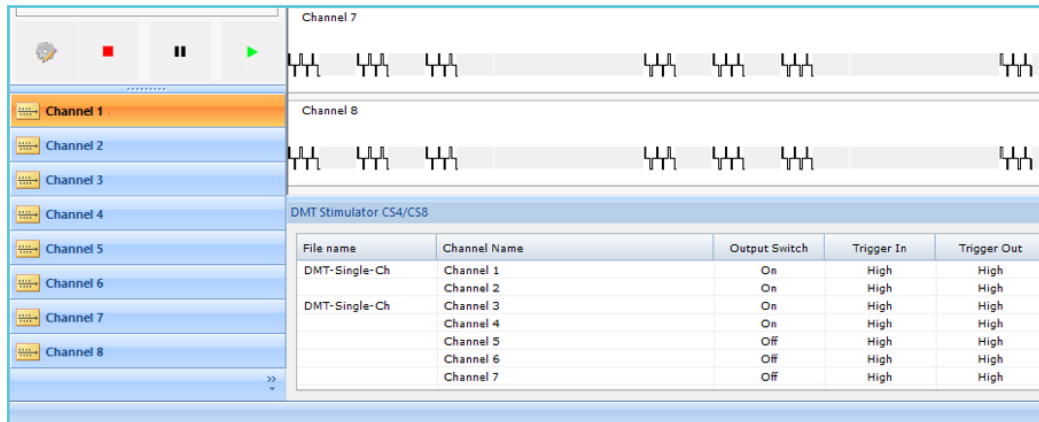

Figure 3.3.6 Copied stimulation file to Channel 1

D) 'Change Description': Will edit the current name or description of the protocol for the specific channel (figure 3.3.7).

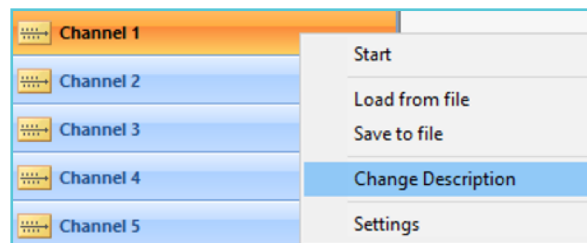

Figure 3.3.7 Channel Description change

It is important to edit the description of the particular channel whose Stimulation protocol has been altered using the 'Change Description' so that the name of this protocol is loaded for that specific channel. For instance, if Channel 1 is running a protocol which is different from the other channels, then under 'Change description' enter the new name as shown in figure 3.3.8.

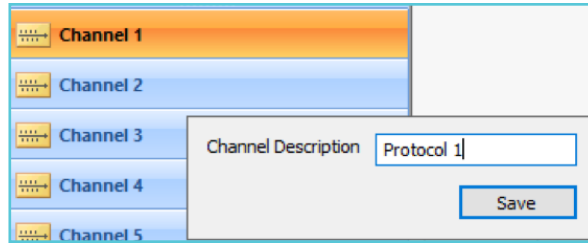

Figure 3.3.8 Channel description

The description or name of the protocol will be shown in the Channel Name column, in the lower panel of the MyoPULSE where the status of the stimulator is shown.

E) 'Settings': Will display the Stimulation guide to create a protocol with defined settings for ONLY a single channel. In figure 3.3.9 below is an example for Channel 3, clicking on 'Settings' and altering the stimulation protocol, will change the stimulation protocol ONLY for Channel 3 whilst the others will remain unchanged unless individually edited as described here

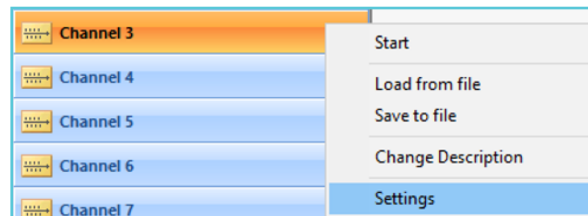

Figure 3.3.9 Editing a protocol in a specific channel

Clicking on 'Settings' will lead you to edit the stimulation protocol (figure 3.3.10) for that particular channel number.

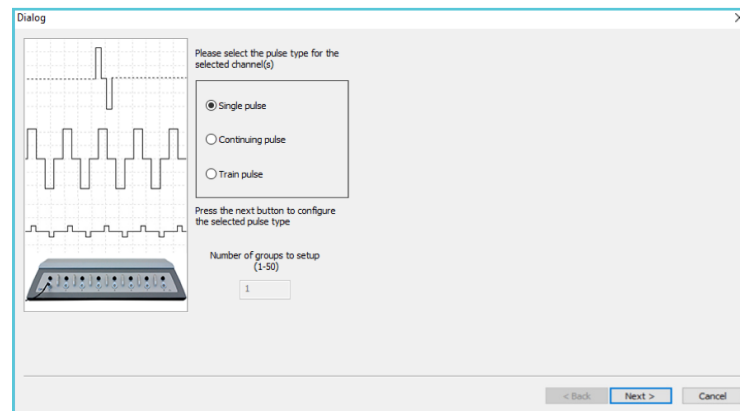

Figure 3.3.10 The Stimulation Protocol Guide window.

3.4 STIMULATION PROTOCOL GUIDE

Go to the 'Home' Menu, click on the 'Configure Channels' to make the same stimulation protocol for all four (CS4 and CS4+) or eight channels (CS8) or right click a given channel and click on 'Settings' to make a stimulation protocol for a single channel as described in the Configure Channels section.

The stimulation protocol guide will start up and the protocol will automatically be loaded into the stimulator when the stimulation protocol guide is finished.

There are 3 different Stimulation Protocol Pulse types in the MyoPULSE (see definitions within the MyoPULSE in Chapter 3.1)

3.4 STIMULATION PROTOCOL GUIDE

Go to the 'Home' Menu, click on the 'Configure Channels' to make the same stimulation protocol for all four (CS4 and CS4+) or eight channels (CS8) or right click a given channel and click on 'Settings' to make a stimulation protocol for a single channel as described in the Configure Channels section.

The stimulation protocol guide will start up and the protocol will automatically be loaded into the stimulator when the stimulation protocol guide is finished.

There are 3 different Stimulation Protocol Pulse types in the MyoPULSE (see definitions within the MyoPULSE in Chapter 3.1)

3.4.1 SINGLE PULSE PROTOCOLS

Select the pulse type for the channel (figure 3.4.1). Here the 'Single Pulse' Stimulation protocol is selected and press Next.

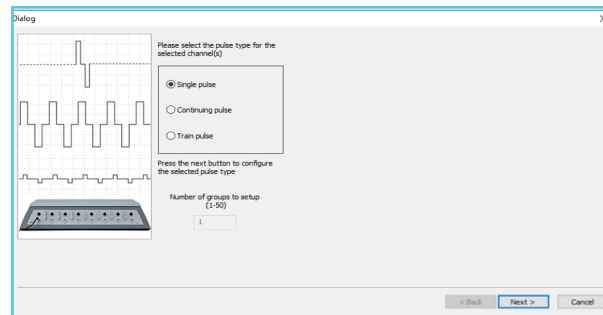

Figure 3.4.1 The Stimulation Protocol Guide window.

Bipolar: The first single stimulus will be positive and the next single stimulus will be a negative if repeated (figure 3.4.2).

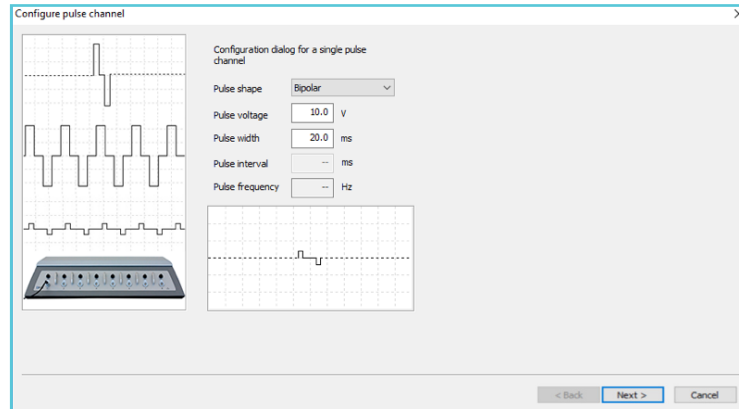

Figure 3.4.2 The Stimulation Protocol Guide window.

This is because the MyoPULSE is programmed to remember that the next pulse must be oppositely charged to the previous pulse.

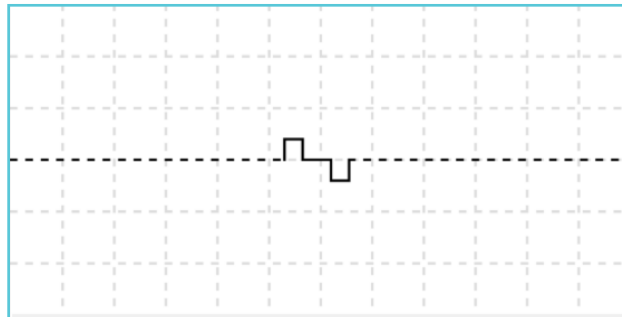

Figure 3.4.3

Positive Monopolar: Single Positive voltage pulse (figure 3.4.4).

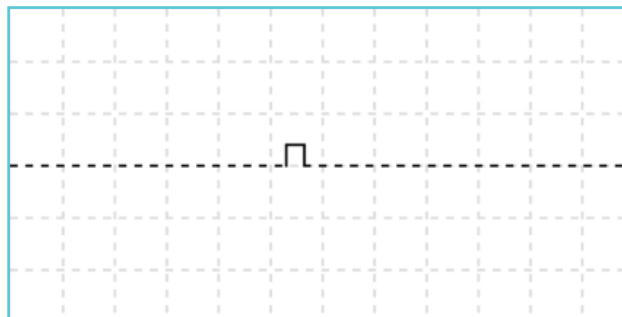

Figure 3.4.4

Negative Monopolar Single Negative voltage pulse (figure 3.4.5).

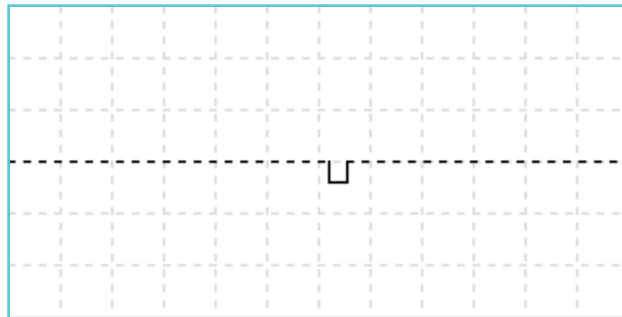

Figure 3.4.5

Next, set the Pulse voltage of the 'Single Pulse'. In MyoPULSE, the voltage can be set between 0 and 31 volts depending on the Pulse width. In table 3.4.6, the maximum 'Pulse voltage' that can be entered is listed for different 'Pulse width' times.

Max Pulse Voltage (volt) CS4/CS8	Max Pulse Voltage (volt) CS4+	Pulse width (msec)	CS4/CS8 Max Volt/ cm (840MD/820MS)	CS4+ Max Volt/ cm (840MD/820MS)
24	45	0.1 - 25	30	56,25
28	60	0.1 - 15	35	75
30	70	0.1 - 5	37.5	87,5
31	80	0.1 - 1	38,75	100

Table 3.4.6 The Scheme shows the maximum Pulse voltage possible corresponding to the different ranges of Pulse widths. (In the Max Volt/cm column, the values are displayed for the NFS coverlids for the Muscle Strip Myograph System-840MD and the Muscle Strip Myograph System - 820MS (electrode distance is 0.8 cm)

The next step is the Digital Input settings which is to define when the stimulator should begin the stimulation protocol.

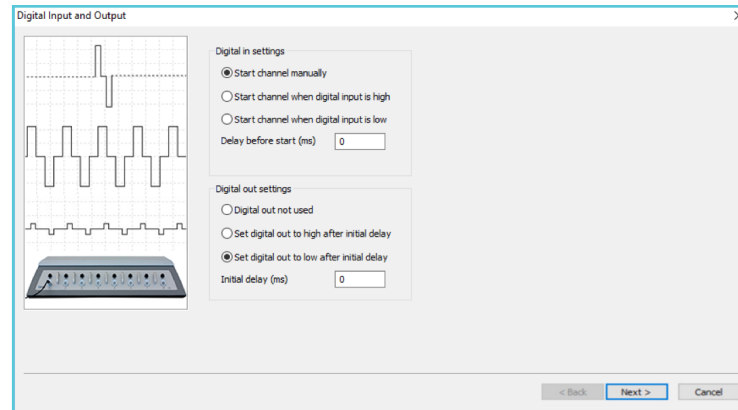

Figure 3.4.7 The Stimulation Protocol Guide window.

In MyoPULSE there are three different 'Digital In settings' and 'Digital out settings' possible for starting the stimulation protocol or sending a trigger to an external system (figure 3.4.7) as e.g the 840MD MyoDynamics Muscle Strip myograph system to trigger the start of the build-in motors.

Digital In Settings:

a) Start Channel manually: Use 'Start all channels' in the Control sub menu in the Home menu (figure 3.4.9).

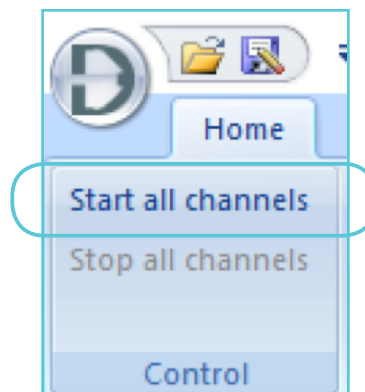

Figure 3.4.8

Alternatively, a specific channel can be started by clicking on the channel to highlight it. Then click the 'Play Button' in the Channel status window shown in figure 3.4.9.

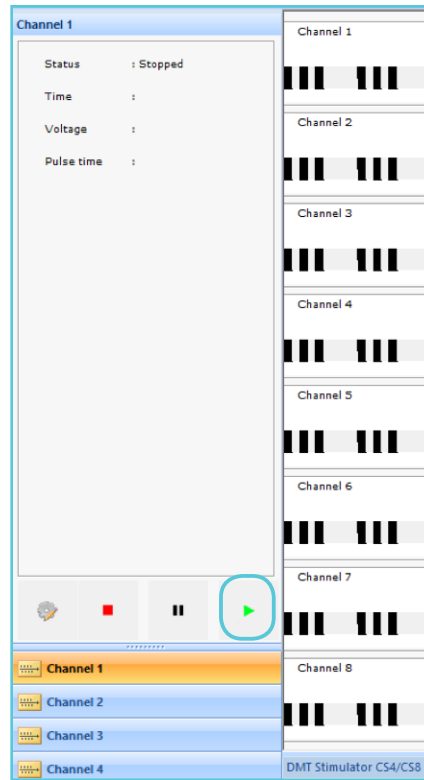

Figure 3.4.9

b) Start when Digital input is high: The CS4 and CS8 stimulator will not start the stimulation protocol before a high voltage trigger input is received (between 6 and 24 volts)

c) Start when Digital input is low: The CS4 and the CS8 stimulator will not start the stimulation protocol before a low voltage trigger input is received (0 volts)

d) Delay before Start (ms): Enter the delay in milliseconds, wanted before the stimulation protocol should start after the trigger was received.

Digital Out Settings:

- a) Digital Output not used: No trigger will be sent.
- b) Set digital output to high after initial delay: A high volt trigger will be sent (6-24 volts) used e.g. for the 840MD MyoDynamics Muscle Strip Myograph System (remember to connect the CS4/CS4+/CS8 stimulator to the 840MD system using the Trigger cables)
- c) Set digital output to low after initial delay: A low trigger will be sent (0 volts)
- d) Initial delay (ms): Enter the delay in milliseconds wanted before the trigger should be sent. If a digital output trigger is chosen with a delay then enter the delay of interest in the initial delay field in milliseconds.

After the setting of the digital Input and output, press Next. The last window in the Single Pulse Configuration is a display of the summary of the settings selected by the user as shown in figure 3.4.10.

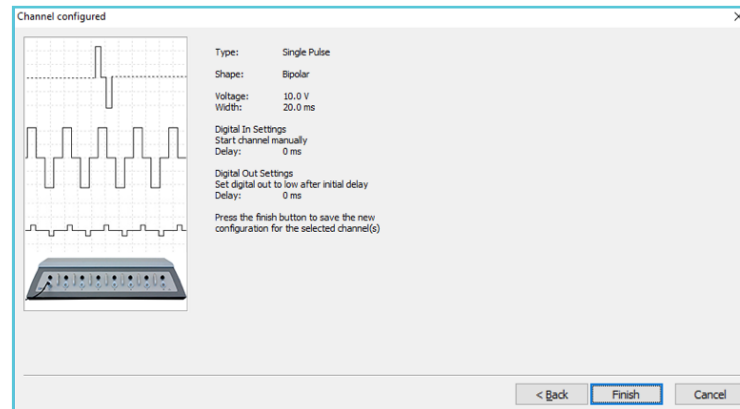

Figure 3.4.10 Single Pulse stimulation protocol summary

NOTE: It is very important to click on 'Finish' otherwise the protocol will not be saved and transferred to the stimulator.

3.4.2 CONTINUING PULSE PROTOCOLS

In the Dialog window for Configure Channel select Continuing pulse and press Next (figure 3.4.11).

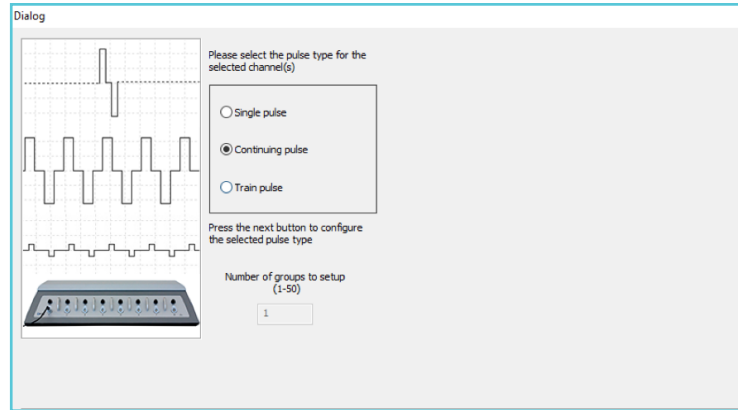

Figure 3.4.11

In the next Configure pulse channel setup window the following parameters have to be set Pulse Shape, Pulse Voltage, Pulse Width, Pulse interval and Pulse frequency (figure 3.4.12).

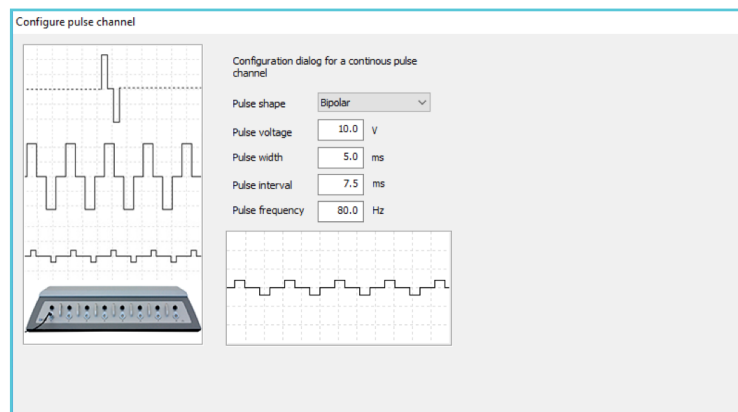

Figure 3.4.12

The Pulse Shape can be set to 3 different types as described below, Bipolar, Positive Monopolar and Negative Monopolar as described below.

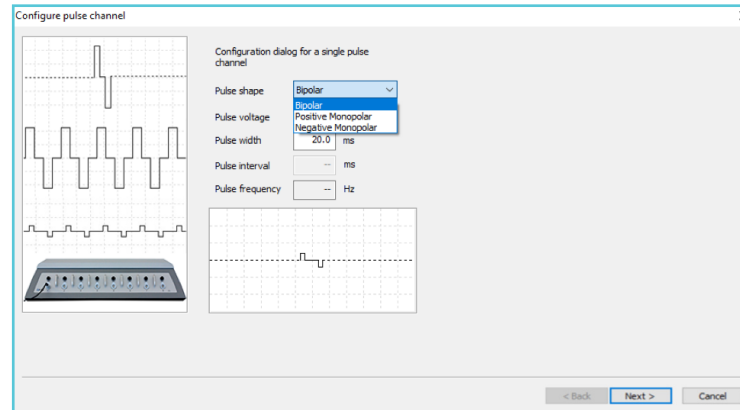

Figure 3.4.13

Bipolar: The first single stimulus will be positive and the next single stimulus will be a negative if repeated. This is because the MyoPULSE is programmed to remember that the next pulse must be oppositely charged to the previous pulse (figure 3.4.14).

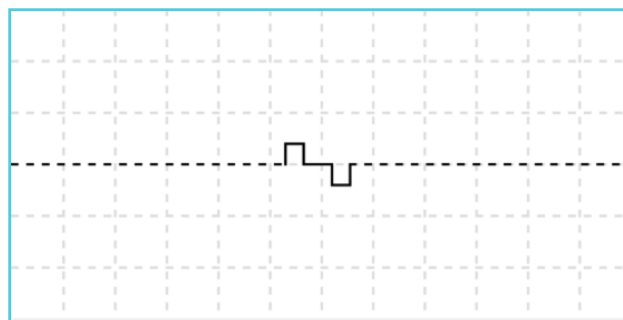

Figure 3.4.14

Positive Monopolar: Single Positive voltage pulse (figure 3.4.15).

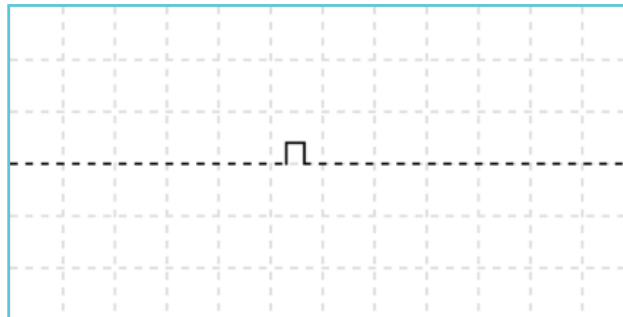

Figure 3.4.15

Negative Monopolar Single Negative voltage pulse (figure 3.4.16).

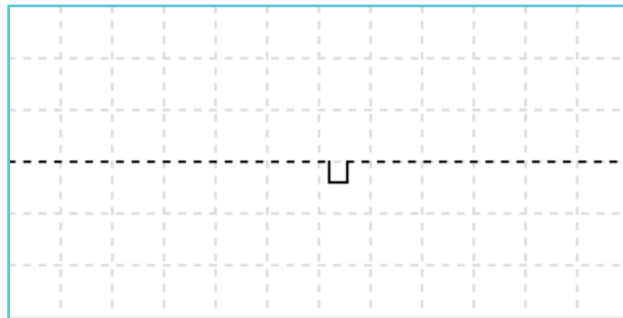

Figure 3.4.16

Next, set the Pulse voltage of the 'Single Pulse'. In MyoPULSE, the voltage can be set between 0 and 31 volts depending on the Pulse width. In the following table 3.4.17, the maximum 'Pulse voltage' that can be entered is listed for different 'Pulse width' times.

Max Pulse Voltage (volt) CS4/CS8	Max Pulse Voltage (volt) CS4+	Pulse width (msec)	CS4/CS8 Max Volt/ cm (840MD/820MS)	CS4+ Max Volt/ cm (840MD/820MS)
24	45	0.1 - 25	30	56,25
28	60	0.1 - 15	35	75
30	70	0.1 - 5	37.5	87,5
31	80	0.1 - 1	38,75	100

Table 3.4.17 The Scheme shows the maximum Pulse voltage possible corresponding to the different ranges of Pulse widths. (In the Max Volt/cm column, the values are displayed for the NFS coverlids for the Muscle Strip Myograph System-840MD and the Muscle Strip Myograph System – 820MS (electrode distance is 0.8 cm)

Next , enter the Pulse Interval in msec or Pulse frequency.

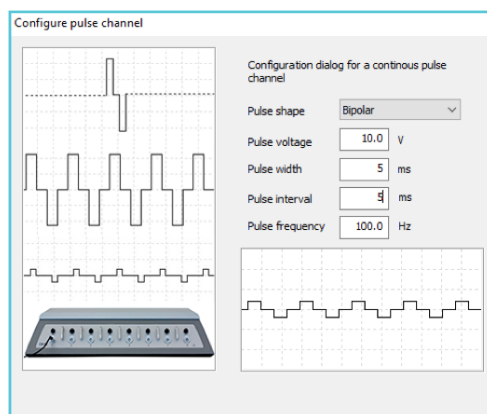

Figure 3.4.18

In the example shown in figure 3.4.18 a Pulse width and interval of 5msec have been selected resulting in a frequency of 100Hz. MyoPULSE will automatically calculate the Pulse frequency based on the Pulse width and the Pulse interval values. As an alternative enter the Pulse frequency and MyoPULSE will automatically calculate the Pulse interval with the fixed Pulse width as shown below where the Pulse frequency have been changed to 50Hz and MyoPULSE then corrects the Pulse interval to 15msec as shown in figure 3.4.19.

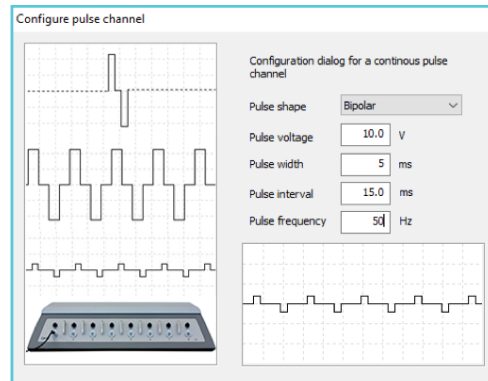

Figure 3.4.19

Then click on 'Next'

The next step is the Digital Input settings which is to define when the stimulator should begin the stimulation protocol (figure 3.4.20).

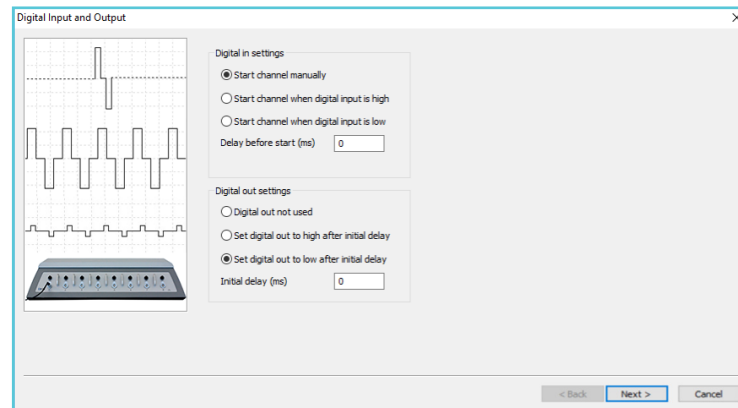

Figure 3.4.20

In MyoPULSE there are three different 'Digital In settings' and 'Digital out settings' possible for starting the stimulation protocol or sending a trigger to an external system as e.g the 840MD MyoDynamics Muscle Strip myograph system to trigger the start of the build-in motors.

Digital In Settings:

a) Start Channel manually: Use 'Start all channels' in the Control sub menu in the Home menu (figure 3.4.21).

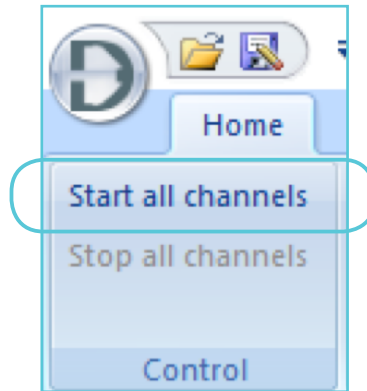

Figure 3.4.21

Alternatively, a specific channel can be started by clicking on the channel to highlight it. Then click the 'Play Button' in the Channel status window shown in figure 3.4.22.

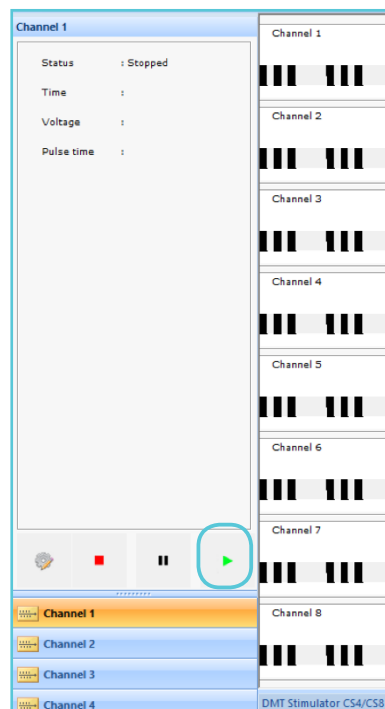

Figure 3.4.22 Highlighted channel with its status window above

b) Start when Digital input is high: The CS4, CS4+ and CS8 stimulator will not start the stimulation protocol before a high voltage trigger input is received (between 6 and 24 volts)

c) Start when Digital input is low: The CS4, CS4+ and the CS8 stimulator will not start the stimulation protocol before a low voltage trigger input is received (0 volts)

d) Delay before Start (ms): Enter the delay in milliseconds, wanted before the stimulation protocol should start after the trigger was received.

Digital Out Settings:

a) Digital Output not used: No trigger will be sent.

b) Set digital output to high after initial delay: A high volt trigger will be sent (6-24 volts) used e.g. for the 840MD MyoDynamics Muscle Strip Myograph System (remember to connect the CS4/CS4+/CS8 stimulator to the 840MD system using the Trigger cables)

c) Set digital output to low after initial delay: A low trigger will be sent (0 volts)

d) Initial delay (ms): Enter the delay in milliseconds wanted before the trigger should be sent. If a digital output trigger is chosen with a delay then enter the delay of interest in the initial delay field in milliseconds.

After the setting of the digital Input and output, press Next. The last window in the Single Pulse Configuration is a display of the summary of the settings selected by the user as shown in figure 3.4.23.

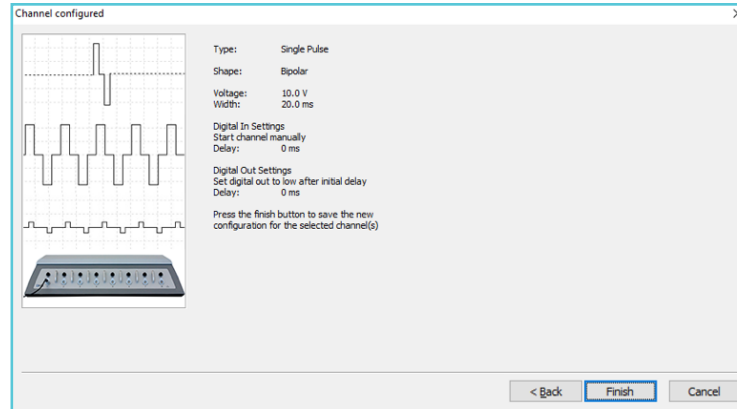

Figure 3.4.23 Continuous Pulse stimulation protocol summary

NOTE: It is very important to click on 'Finish' otherwise the protocol will not be saved and transferred to the stimulator.

The programmed protocol will be graphically shown in figure 3.4.24

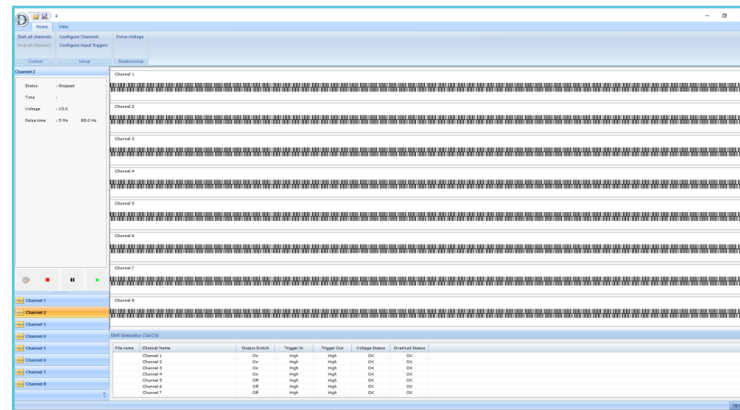

Figure 3.4.24 Overview of the Continuing Pulse Stimulation protocol

3.4.3 TRAIN PULSE PROTOCOLS

The Train Pulse programming in MyoPULSE is completely flexible and will meet all requests. In the Dialog window for Configure Channel select Train Pulse and depending on how many different groups wanted in the stimulation protocol (blue box in figure 2.4.26) enter this number in Number of groups to setup and then press Next. A Group is defined as a train of pulses with the same pulse width and Pulse interval. An example of a protocol with three different Groups of trains is shown schematic below in figure 3.4.25.

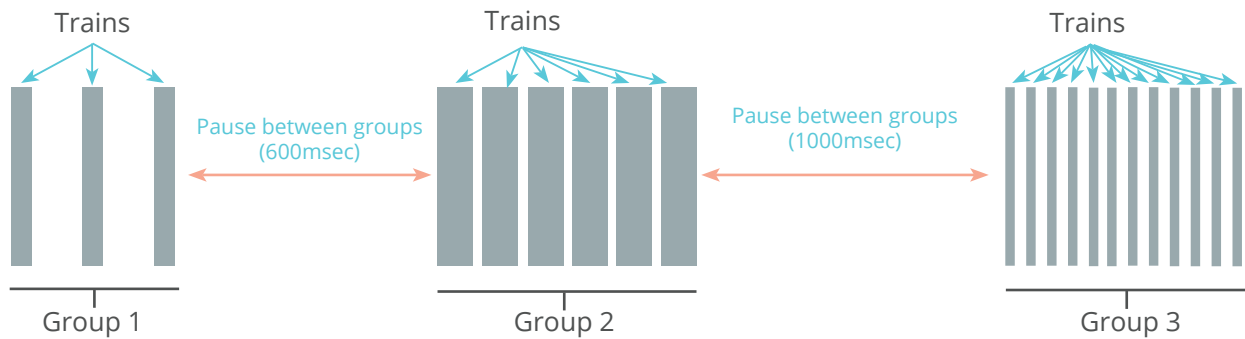

Figure 3.4.25 An example on a protocol with three different groups of train pulses

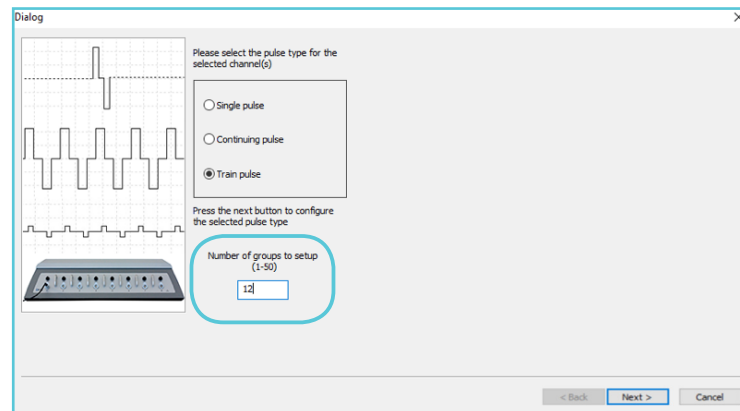

Figure 3.4.25

NOTE: It is a very good idea to design your protocol and make a sketch of it on a piece of paper to identify how many different groups the complete protocol will contain. If the Pulse voltage, Pulse width or Pulse frequency has to be changed a new Group has to be defined.

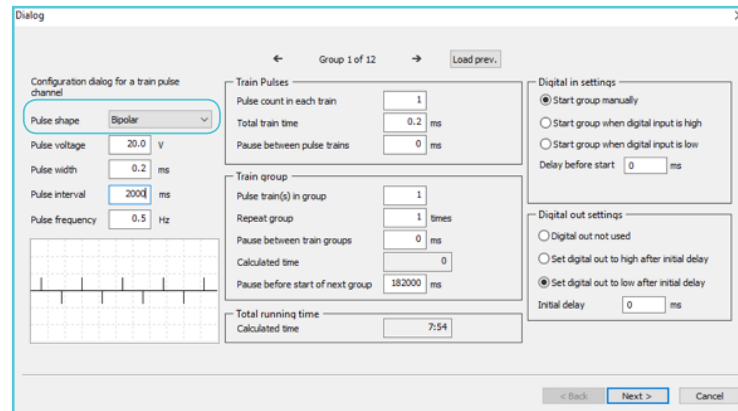

Figure 3.4.27

The Pulse Shape can be set to 3 different types (figure 3.4.27) as described below, Bipolar, Positive Monopolar and Negative Monopolar as described below.

Bipolar: The first single stimulus will be positive and the next single stimulus will be a negative if repeated. This is because the MyoPULSE is programmed to remember that the next pulse must be oppositely charged to the previous pulse.

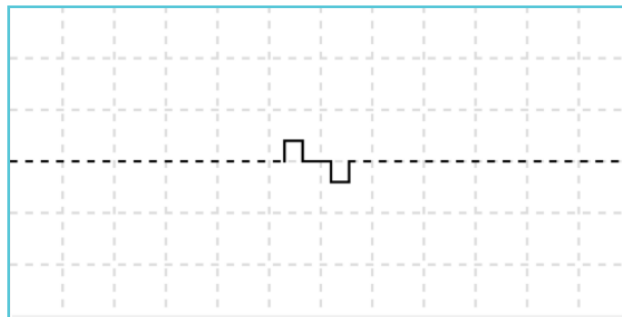

Figure 3.4.28

Positive Monopolar: Single Positive voltage pulse

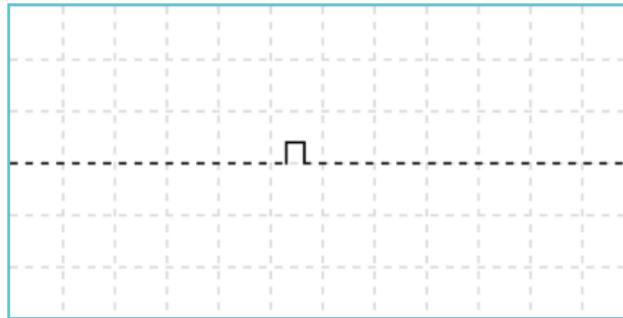

Figure 3.4.29

Negative Monopolar Single Negative voltage pulse

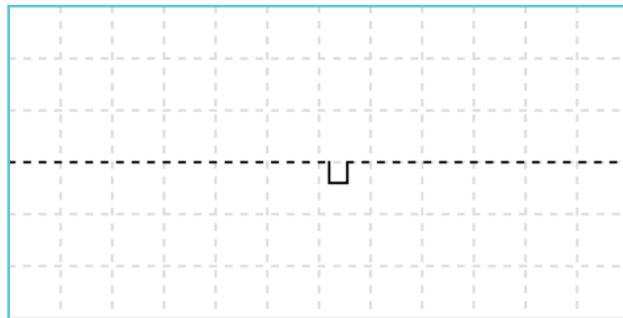

Figure 3.4.30

Next, set the Pulse voltage. In MyoPULSE, the voltage can be set between 0 and 80 volts depending on the pulse width and stimulator. In table 3.4.31, the maximum 'Pulse voltage' that can be entered is listed for different 'Pulse width' times in Milliseconds (ms) and the type of Stimulator (CS4, CS4+ and CS8).

Max Pulse Voltage (volt) CS4/CS8	Max Pulse Voltage (volt) CS4+	Pulse width (msec)	CS4/CS8 Max Volt/ cm (840MD/820MS)	CS4+ Max Volt/ cm (840MD/820MS)
24	45	0.1 - 25	30	56,25
28	60	0.1 - 15	35	75
30	70	0.1 - 5	37.5	87,5
31	80	0.1 - 1	38,75	100

Table 3.4.31 The Scheme shows the maximum Pulse voltage possible corresponding to the different ranges of Pulse widths. (In the Max Volt/cm column, the values are displayed for the NFS coverlids for the Muscle Strip Myograph System-840MD and the Muscle Strip Myograph System – 820MS (electrode distance is 0.8 cm)

Next , enter the Pulse Interval in msec or Pulse frequency (figure 3.4.32).

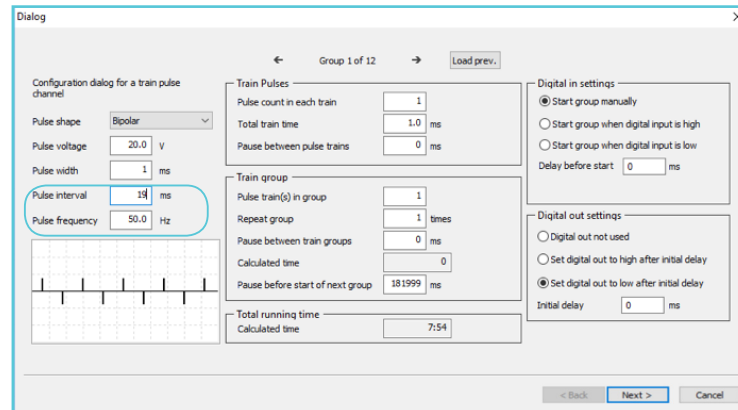

Figure 3.4.32

In the example in figure 3.4.32 a Pulse width of 1msec and Pulse interval of 19msec have been selected resulting in a frequency of 50Hz. MyoPULSE will automatically calculate the Pulse frequency based on the Pulse width and the Pulse interval values. As an alternative enter the Pulse frequency and MyoPULSE will automatically calculate the Pulse interval with the fixed Pulse width as shown in figure 3.4.33 where the Pulse frequency have been changed to 100Hz and MyoPULSE then corrects the Pulse interval to 9.0msec.

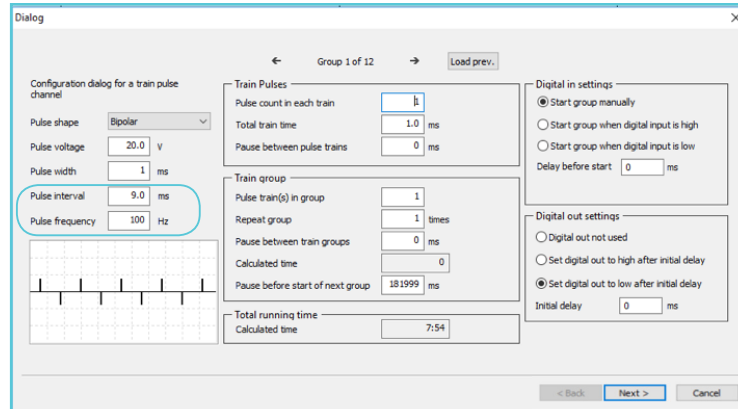

Figure 3.4.33

The next parameters to enter define Train pulses (blue box in the figure below).

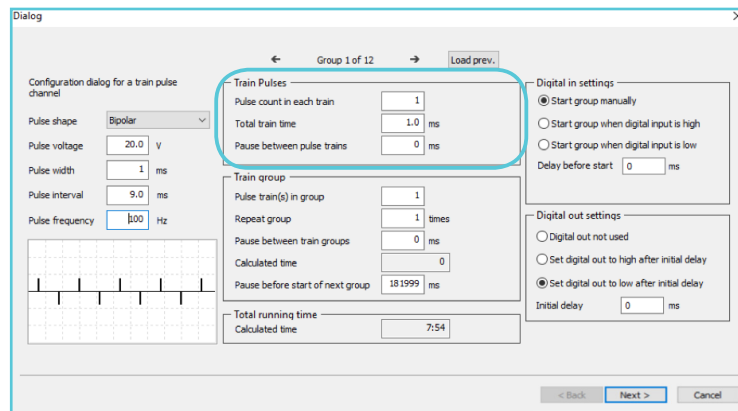

Figure 3.4.34

Pulse count in each train: The number of pulses wanted in a train can be entered. When a number is entered MyoPULSE will calculate the Total train time automatically. As shown in figure 3.4.35 if 10 pulse count is entered the Total train time will be 91.0msec.

Train Pulses	
Pulse count in each train	<input type="text" value="10"/>
Total train time	<input type="text" value="91.0"/> ms
Pause between pulse trains	<input type="text" value="0"/> ms

Figure 3.4.35

Total Train time: The train time can be entered in msec. When the Total train time is entered MyoPULSE will calculate the Pulse count in each train automatically. By entering e.g. 500msec as a train time the Pulse count in each train will be changed to 50 pulses as shown in figure 3.4.36.

Train Pulses	
Pulse count in each train	<input type="text" value="50"/>
Total train time	<input type="text" value="491.0"/> ms
Pause between pulse trains	<input type="text" value="0"/> ms

Figure 3.4.36

NOTE: MyoPULSE will not include the last Pulse interval time after the last pulse in a train in the Total train time calculation. In the above example the 500msec Total train time is auto-corrected to 491.0msec because the 9.0msec Pulse interval is not included.

If last Pulse interval needs to be included then add the time (here 9.0msec) to either the Pause between pulse trains or Pause before start of next group.

Pause between pulse trains: Defines the time (msec) between Trains. In figure 3.4.37 the Pause is set to 1000msec.

Train Pulses	
Pulse count in each train	<input type="text" value="50"/>
Total train time	<input type="text" value="491.0"/> ms
Pause between pulse trains	<input type="text" value="1000"/> ms

Figure 3.4.37

If the last Pulse interval time after the last pulse in the train is important the add this to the Pause between pulse trains as shown in figure 3.4.38 where the 9.0msec have been added

Train Pulses	
Pulse count in each train	<input type="text" value="50"/>
Total train time	<input type="text" value="491.0"/> ms
Pause between pulse trains	<input type="text" value="1009"/> ms

Figure 3.4.38

Train Group: The next parameters to enter define Train group (blue box in the figure 3.4.39).

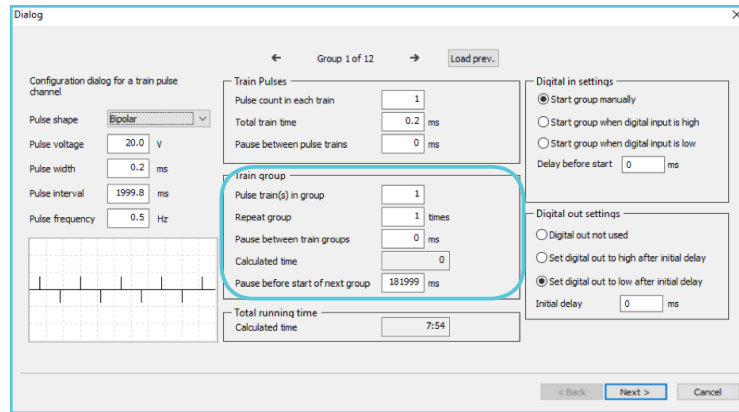

Figure 3.4.39

Pulse train(s) in group: The number of trains wanted in a group can be entered. Entering the value 1 the train will run once.

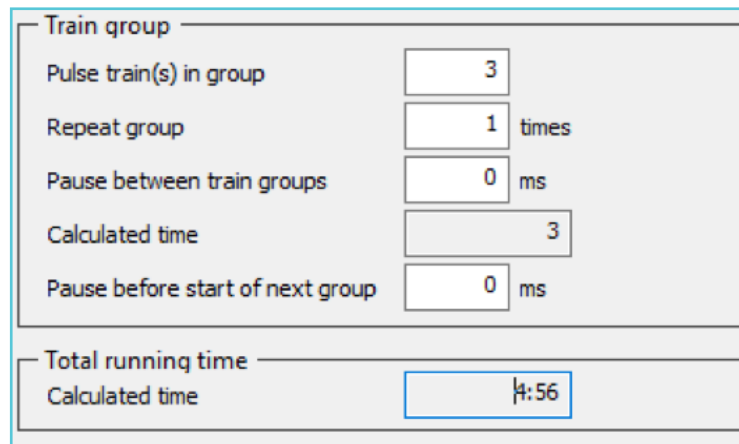

Figure 3.4.40

Entering 3 means that the train will be repeated three times (figure 3.4.40).



Repeat group: The number of times the group will be run. Entering the value 1 will run a group once.

Train group	
Pulse train(s) in group	<input type="text" value="3"/>
Repeat group	<input type="text" value="2"/> times
Pause between train groups	<input type="text" value="0"/> ms
Calculated time	<input type="text" value="7"/>
Pause before start of next group	<input type="text" value="0"/> ms
Total running time	
Calculated time	<input type="text" value="4:59"/>

Figure 3.4.41

Entering 2 means that the group will run two times (figure 3.4.41 and 3.4.42).



Figure 3.4.42

Pause between train groups: Define the time between groups in msec. In figure 3.4.43 and 3.4.44 the pause have been set to 60000msec equal to 1min

Train group	
Pulse train(s) in group	<input type="text" value="3"/>
Repeat group	<input type="text" value="2"/> times
Pause between train groups	<input type="text" value="60000"/> ms
Calculated time	<input type="text" value="1:07"/>
Pause before start of next group	<input type="text" value="0"/> ms
Total running time	
Calculated time	<input type="text" value="5:59"/>

Figure 3.4.43

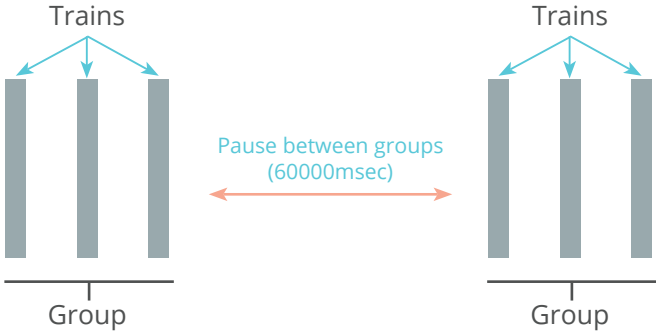

Figure 3.4.44

Calculated time: MyoVIEW will calculate the total time for running the group.

Pause before start of next group: Set the time between this defined Group and the next Group (blue box) to be defined (figure 3.4.45).

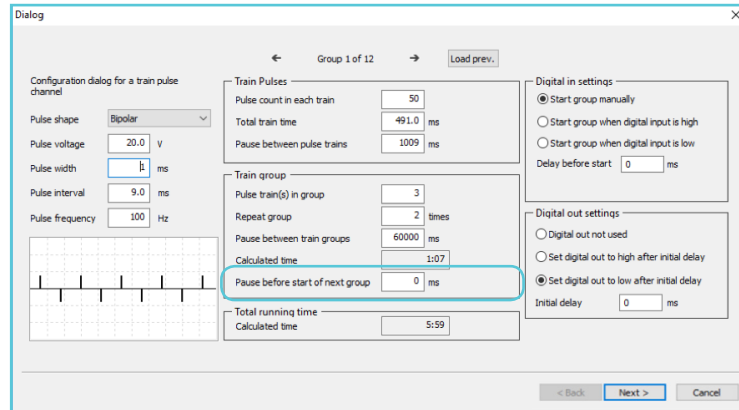

Figure 3.4.45 Overview of the first group in the Train Stimulation protocol

The above Group will look like the scheme in figure 3.4.46.

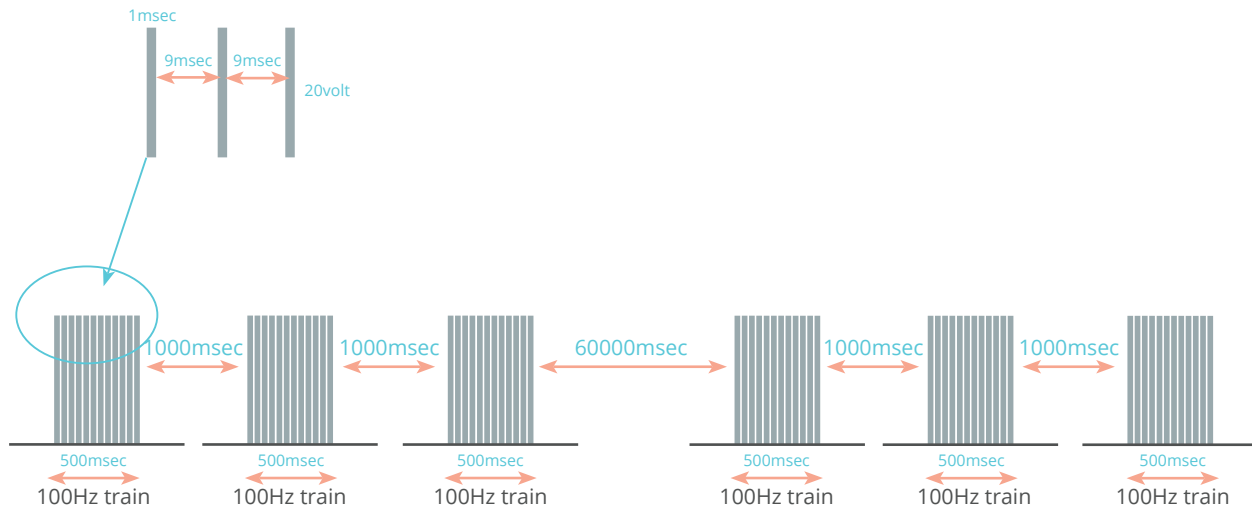

Figure 3.4.46 Overview of the first group in the Train Stimulation protocol

The next parameters to select is the Digital in settings and Digital out settings (figure 3.4.47). The Digital in settings is used to define when the stimulator should begin the stimulation protocol.

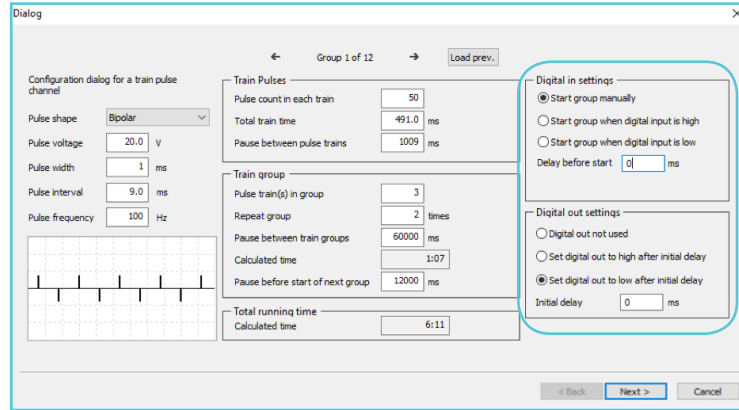

Figure 3.4.47

After the setting of the Digital in settings and Digital out settings start defining the next Group if several Groups need to be programmed by pressing the 'forward' arrow icon marked with the blue box in figure 3.4.48.

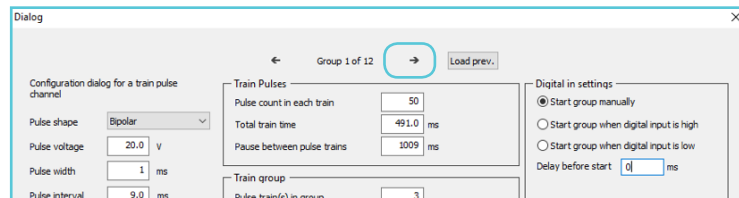

Figure 3.4.48

Programming of additional Groups

Pressing the 'forward' arrow icon marked with the blue box in the 3.4.48 above will open Group 2 as show in figure 3.4.49. The values listed for all the parameters could be from a former program in the stimulator.

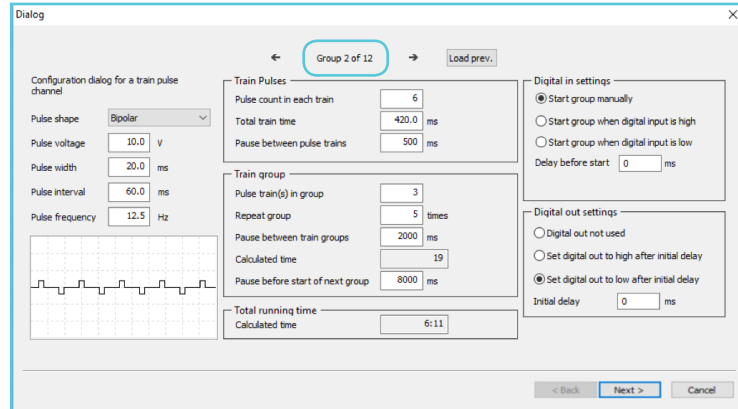

Figure 3.4.49

To get the exact same values for the different parameters as defined for the former Group press the icon Load prev. as shown in figure 3.4.50.

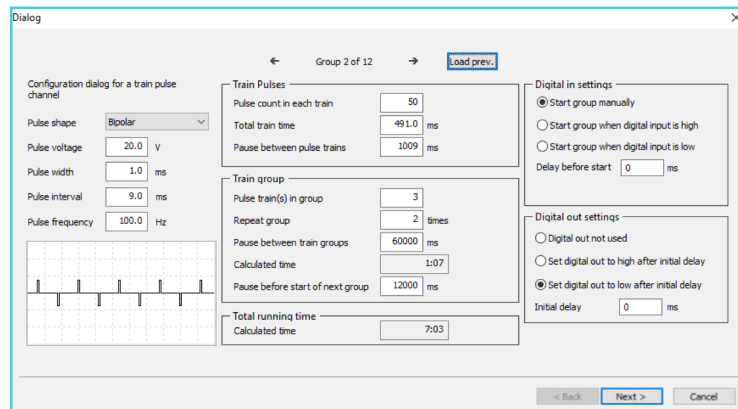

Figure 3.4.50

The different parameters can then be changed according to the appropriate protocol needed. The next Group can then be defined until all 12 Groups have been made.

NOTE: All groups has to be defined.

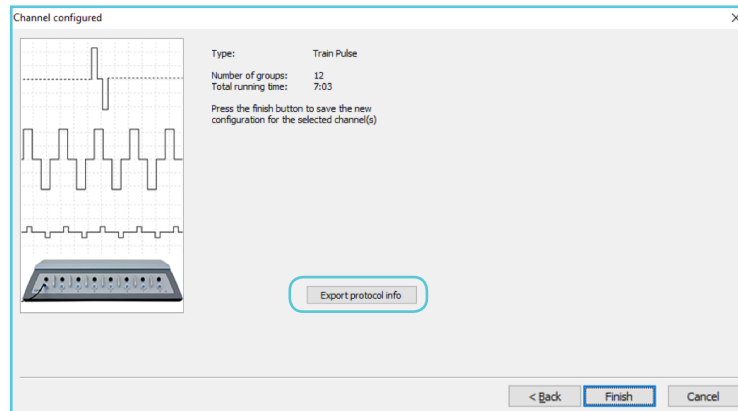

Figure 3.4.51

After the last group have been made press Next.

The last window in the Train Pulse Configuration is a display of the summary of the settings selected by the user as shown in figure 3.4.51.

To see the Train Pulse configuration in more details the protocol programmed can be exported in a txt-file format by pressing the Export protocol info. In figure 3.4.52 an example of the exported protocol can be seen.

```
DMT-test - Notesblok
Filer Rediger Formater Vis Hjælp
** Stimulator Protocol **

Type:                               Train Pulse
Groups:                              12
Total time:                          7:03

-----

Group:                                1

Pulse shape:                         Bipolar
Pulse voltage:                       20.0 V
Pulse width:                         1.0 ms
Pulse interval:                      9.0 ms
Pulse frequency:                     100.0 Hz

Train pulses
Pulse count in each train:           50
Total train time:                   491.0 ms
Pause between pulse trains:         1009 ms

Train group
Pulse train(s) in group:             3
Repeat group:                        2
Pause between train groups:         60000 ms
Calculated time:                    1:06
Pause before start of next group: 12000 ms

Digital in settings
Start channel manually
Delay before start:                  0 ms

Digital out settings
Set digital out to low after initial delay
Initial delay:                      0 ms

-----
```

Figure x.x

To transfer the Train Pulse Configuration to the CS4/CS4+/CS8 stimulator press the Finish button (figure 3.4.53).

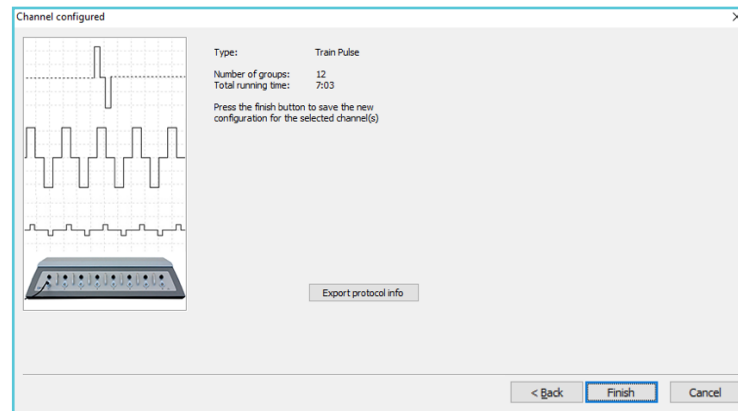

Figure 3.4.53 Train Pulse stimulation protocol summary



WARNING: IT IS VERY IMPORTANT TO CLICK ON 'FINISH' OTHERWISE THE PROTOCOL WILL NOT BE SAVED AND UPLOADED TO THE STIMULATOR.

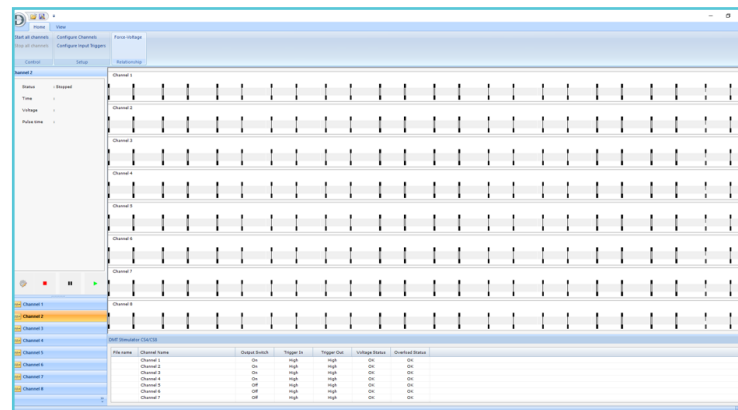

Figure 3.4.54 Overview of the Train Pulse Stimulation protocol

In figure 3.4.54 the outline of the stimulation protocol can be seen.

CHAPTER 4 - EXPERIMENTAL SETUP

4.1 STARTING A STIMULATION PROTOCOL

The CS4 and CS8 stimulator have the ON/OFF output switches for each channel.



Figure 4.1 CS4 Stimulator - ON/OFF switch

If an Output switch is in the OFF position, e.g. for '3' it is not possible to start a stimulation protocol for that given channel on the MyoPULSE (Channel 3). Therefore, it is very important that the user turns the appropriate switches in the ON position corresponding to those Channel numbers being operated on the MyoPULSE. In the status window, the status of the Output switch is shown as encircled in the figure 4.1.2 in blue.

The screenshot shows the 'DMT Stimulator CS4/CS8' status window. On the left is a vertical list of channels from 1 to 8. The main area contains a table with the following data:

File name	Channel Name	Output Switch	Trigger In	Trigger Out	Voltage Status	Overload Status
	Channel 1	On	High	High	OK	OK
	Channel 2	On	High	High	OK	OK
	Channel 3	On	High	High	OK	OK
	Channel 4	On	High	High	OK	OK
	Channel 5	Off	High	High	OK	OK
	Channel 6	Off	High	High	OK	OK
	Channel 7	Off	High	High	OK	OK

Figure 4.1.2 CS4/CS4+/CS8 Stimulator status - Output switch

Before the CS4, CS4+ and CS8 stimulator can start a stimulation protocol you have FOUR different options to get started as illustrated below:

1. Make a stimulation protocol for all channels using the 'Configure channels' in the 'Setup' sub menu in the 'Home' menu (figure 4.1.3).

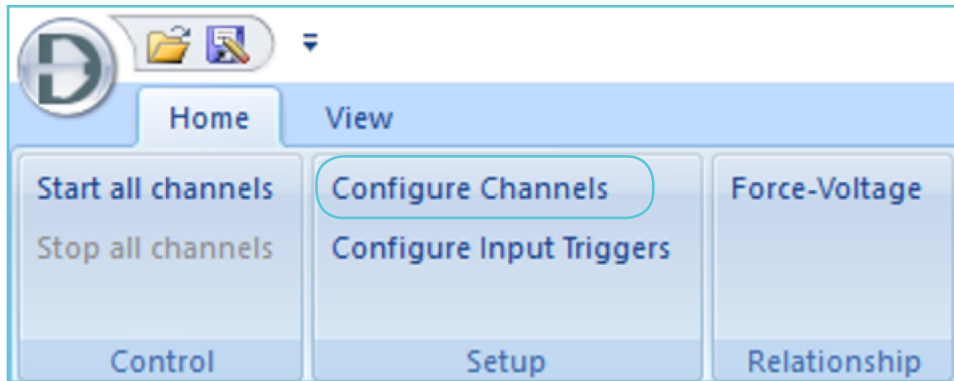

Figure 4.1.3 Opening an existing protocol to load into All channels.

OR

2. Make a stimulation protocol for a single specific channel by right clicking on that given channel and select 'Settings' (figure 4.1.4).

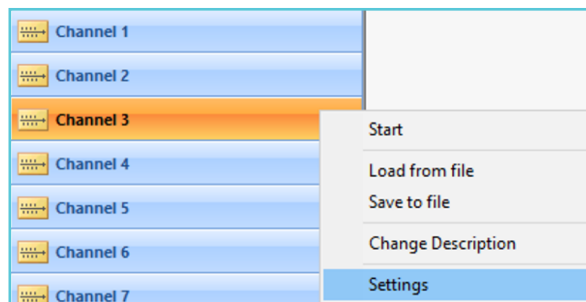

Figure 4.1.4 'Load from file' for an individual channel (Channel 3 here)

3. Load a stimulation Protocol for all channels by clicking on the icon 'D' and 'Open' in the top left corner/ application button (*.pls files) as shown in figure 4.1.5.

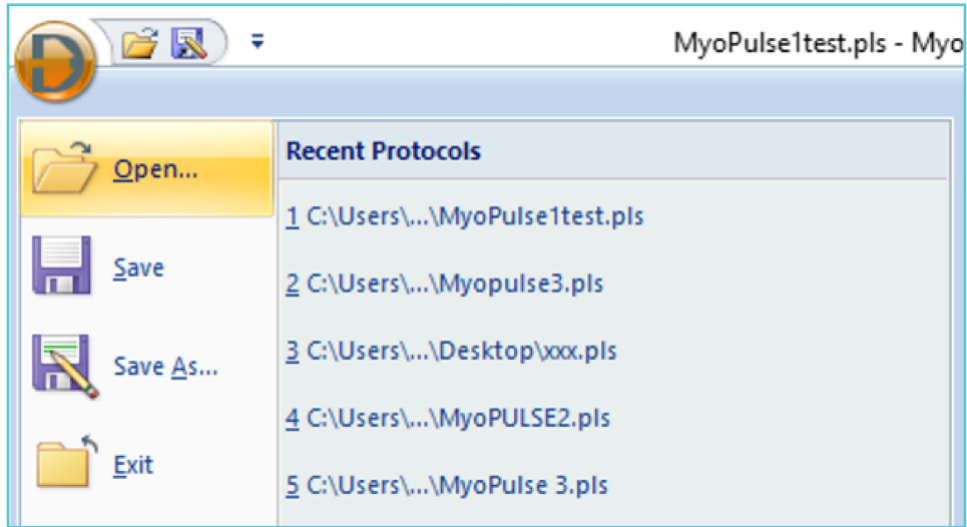

Figure 4.1.5 Opening an existing protocol to load into All channels

OR

4. Load a stimulation protocol for only one specific channel by right clicking on the given channel and select 'Load from file' and select the appropriate file (*.plc files).

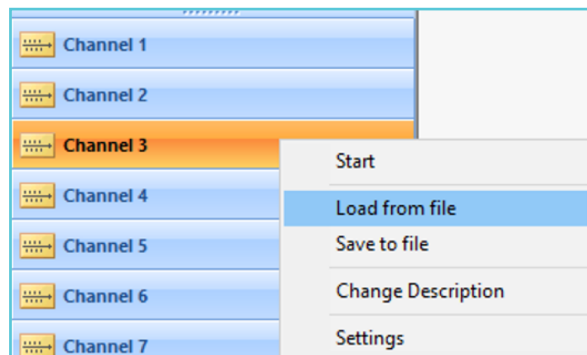

Figure 4.1.6 'Load from file' for an individual channel (Channel 3 here)

NOTE: A stimulation file made for all 'four or eight channels' depending on if it's a CS4 or a CS8 stimulator respectively cannot be loaded into a 'single channel' and vice versa. Files for 4 and 8 channels have the extension pls and single channel protocol files plc.

After a stimulation protocol has been loaded or made for the channels (It is possible to have different protocols for each channel), the stimulation protocols can be started in TWO ways:

1. 'Start all Channels' in the 'Control' sub menu in the 'Home' menu (figure 4.1.7). This will start the stimulation protocols of all channels simultaneously running the Stimulation protocol loaded/made for each channel.

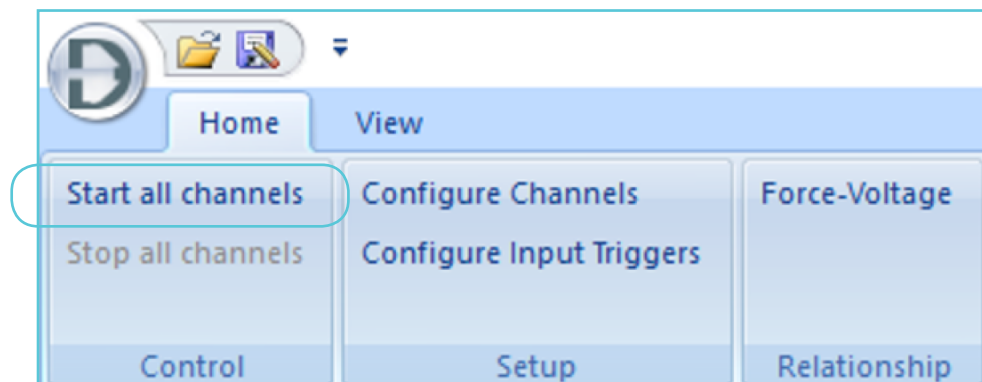

Figure 4.1.7 Clicking on 'Start all channels'

OR

2. Start a stimulation protocol for only one specific channel by clicking on e.g. Channel 1 which lights up in orange followed by clicking on the small 'Play button' arrow in the Channel status window as encircled and shown in figure 4.1.8.

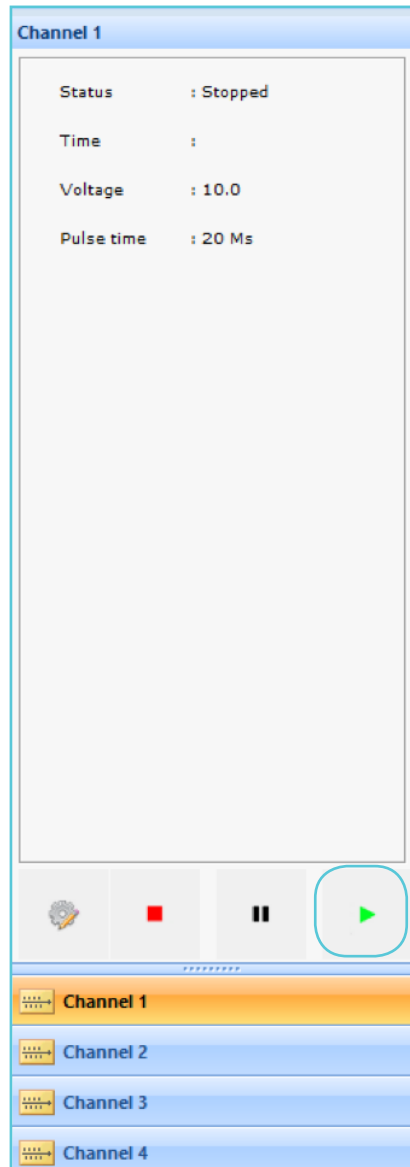

Figure 4.1.8 Play Button for Channel 1

This will only start the stimulation protocol for Channel 1 as shown in figure 4.1.9:

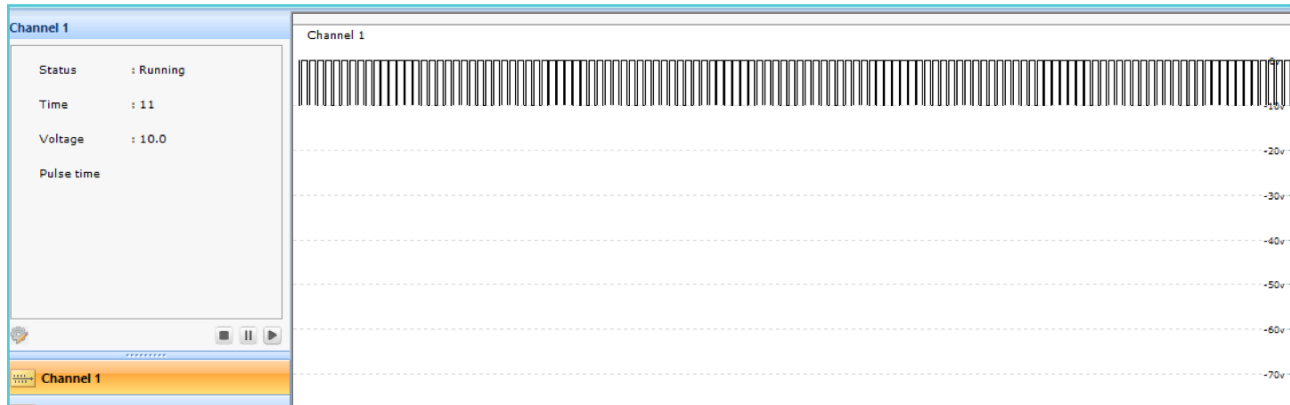

Figure 4.1.9 Stimulation protocol for Channel 1

NOTE: Remember to put the appropriate channel output switches to the ON position BEFORE starting a stimulation protocol.

4.2 SAVING A STIMULATION PROTOCOL

After the stimulation protocol for a single channel or various channels have been made, the protocols can be saved and opened in TWO ways:

1. By Clicking on 'D' and selecting 'Save as' (figure 4.2.1), eg 'Protocol 1' the protocols loaded/created for all channels will be saved into a single file where the protocols for each channel can be identical or completely different (figure 4.2.2). Then, by selecting 'Open' an existing saved stimulation protocol file for all channels can be loaded.

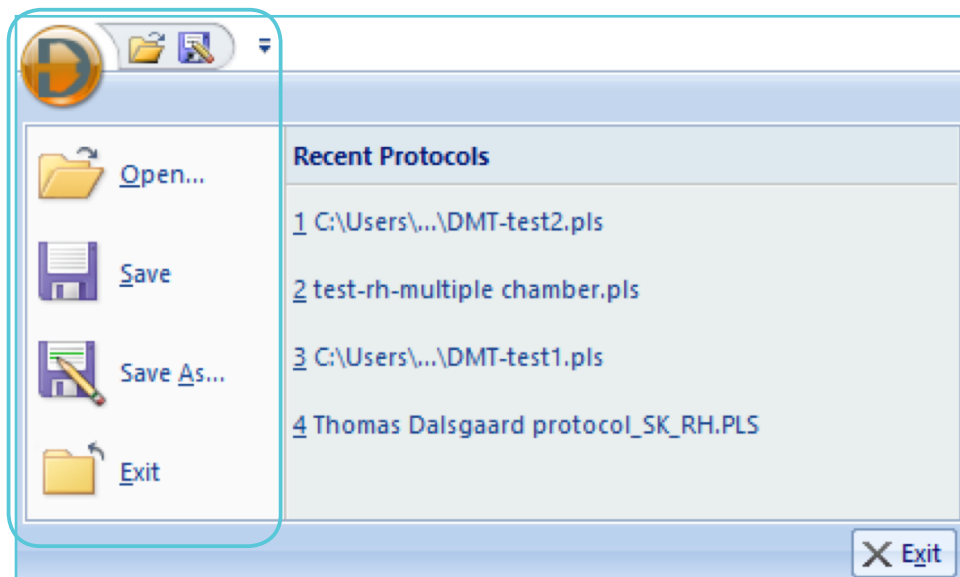

Figure 4.2.1

DMT Stimulator CS4/CS4+/CS8	
File name	Channel Name
Protocol1	Channel 1
Protocol1	Channel 2
Protocol1	Channel 3
Protocol1	Channel 4
Protocol1	Channel 5
Protocol1	Channel 6
Protocol1	Channel 7

Figure 4.2.2 Saving a stimulation protocol for Channel 1

OR

- By saving a protocol for a single channel right click on the channel and press save as shown in figure 4.2.3. The file will get the file extension plc.

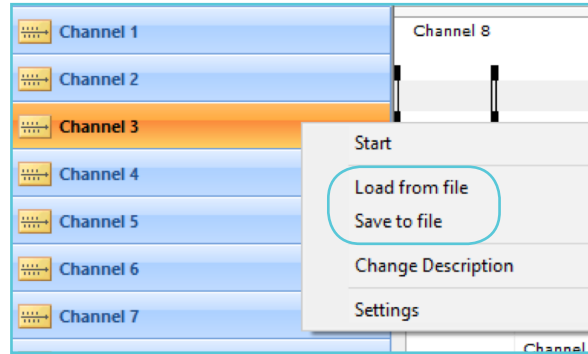

Figure 4.2.3

This file can now be loaded into any other single channel of choice by pressing Load from file (figure 4.2.3). Select a single channel file (*.plc) e.g. as shown in figure 4.2.4 the protocol 'Single-channel-test2' has been selected and loaded. The File names loaded into each channel is listed in the column File name.

File name	Channel Name	Output Switch	Trigger In	Trigger Out	Voltage Status	Overload Status
DMT-test2	Channel 1	On	High	High	OK	OK
DMT-test2	Channel 2	On	High	High	OK	OK
single-channel-test2	Channel 3 : Protocol 1	On	High	High	OK	OK
DMT-test2	Channel 4	On	High	High	OK	OK
DMT-test2	Channel 5	Off	High	High	OK	OK
DMT-test2	Channel 6	Off	High	High	OK	OK
DMT-test2	Channel 7	Off	High	High	OK	OK

Figure 4.2.4 Single channel protocol loaded into channel 3

The schematic overview of the stimulation protocols change, accordingly to the stimulation protocol loaded into MyoPULSE as can be seen in figure 4.2.5 where a channel 3 have been loaded with a different stimulation protocol than all the other channels.

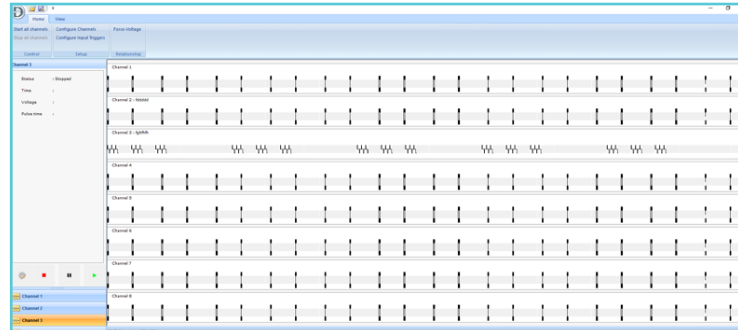

Figure 4.2.5 In the example here, a different stimulation protocol have been loaded for channel 3 by loading a single file protocol (*.plc).

NOTE: Remember to put the appropriate channel output switches to the ON position BEFORE starting a stimulation protocol.

4.3 INPUT TRIGGER

The CS4, CS4+ and CS8 have an input trigger feature making it possible to trigger and start a stimulation protocol from the 840MD MyoDynamics Muscle Strip Myograph System or a Powerlab. All the channels on the CS4, CS4+ and CS8 stimulator can be controlled individually or in groups using the individual Input Trigger ports on the back panel of the CS4, CS4+ and CS8 stimulators. On the back panel of the CS4, CS4+ and CS8, there are two types of plugs, a four pin and a three-pin plug (figure 4.3.1). The four-pin plus are the input Trigger ports and the output Trigger ports are three pin plugs.

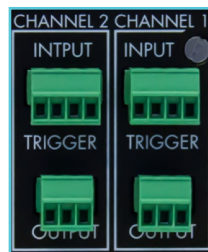

Figure 4.3.1 Input and Output Trigger – Rear panel of CS4 stimulator loaded for channel 3 by loading a single file protocol (*.plc).

The 840MD MyoDynamics Muscle Strip Myograph System is provided with cables fitted to the input and output trigger ports of the CS4, CS4+ and CS8 stimulator making it impossible to connect the stimulator and the MyoDynamics Muscle Strip Myograph System -840MD in a wrong way. The CS4, CS4+ and CS8 need a trigger Input of +6V to +24V (unit protected from damage for input signals to +30 volts) to initiate a Trigger function defined in the Stimulation Protocol setup as shown below where the ‘Digital in setting’ have been selected to start when the Input is high (“Start channel when digital input is high”).

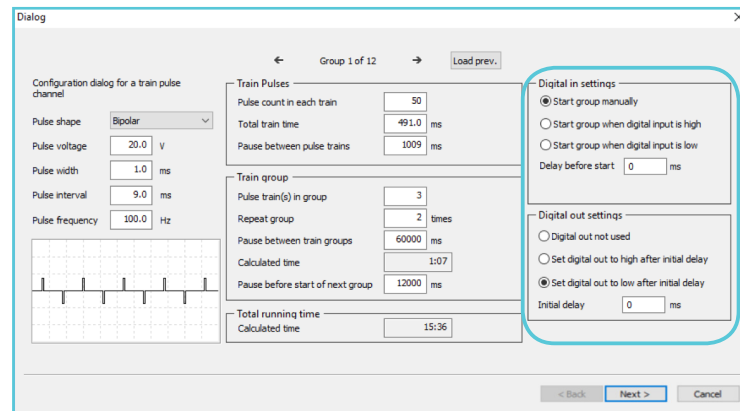

Figure 4.3.2 Trigger function defined in the Stimulation protocol setup shown in the Train Pulse setup as an example

4.3.1 CONFIGURING INPUT TRIGGERS

By clicking on 'Configure Input Triggers' in the 'Setup' sub menu in the 'Home' menu of the MyoPULSE (figure 4.3.3), the input triggers can be set to define a Master Input trigger.

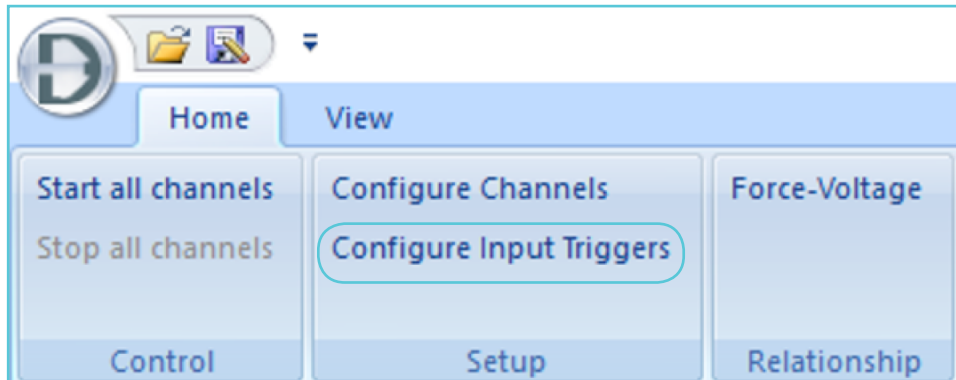

Figure 4.3.3 Configure Input Triggers in the Set sub-menu

For the CS4 and CS4+ stimulator there is ONE Master trigger placed on Channel 1 controlling the trigger in Channel 2, 3 and 4 (figure 4.3.4).

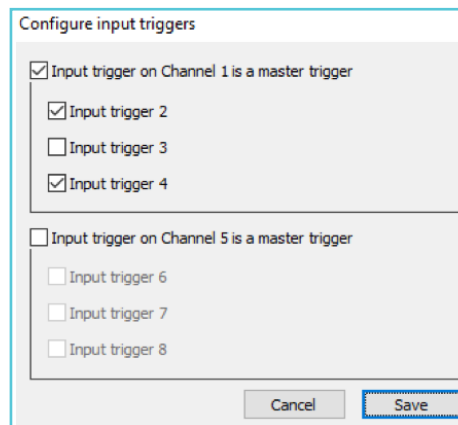

Figure 4.3.4 Configure Input Triggers in the CS4 stimulator

For the CS8 stimulator there are TWO Master triggers,

- one placed on Channel 1 controlling the trigger in Channel 2, 3 and 4
- the other at Channel 5 controlling the trigger in Channel 6, 7 and 8.

By selecting Channel 1 as an input trigger, it means Channel 1 is the Master trigger. Therefore, it is possible to select the channels that should be controlled by the Master trigger in Channel 1. The figure below shows that Channel 1 has been selected as the Master trigger, and by selecting 'Input trigger 2' and 'Input trigger 4' the input trigger received in Channel 1 will also trigger Channel 2 and Channel 4 but NOT channel 3.

NOTE: Remember to click on 'Save' to confirm the settings.

APPENDIX A

SYSTEM CS4/CS8 SPECIFICATIONS

SPECIFICATIONS:	
Output voltage	0-31 Volt
Output	Mono/Bipolar
Stimulus width	0.1-25 m sec.
Max. frequency	2500Hz
Voltage supply	100-240 Volt 50/60Hz to 48 Volt DC 70 Watt power adapter
MyoPULSE software	Windows 7 and Windows 10 Minimum 1 GB of RAM

SYSTEM CS4+ SPECIFICATIONS

SPECIFICATIONS:	
Output voltage	0-80 Volt
Output	Mono/Bipolar
Stimulus width	0.1-25 m sec.
Max. frequency	2500Hz
Voltage supply	100-240 Volt 50/60Hz to 48 Volt DC 70 Watt power adapter
MyoPULSE software	Windows 7 and Windows 10 Minimum 1 GB of RAM

APPENDIX B

The MyoPULSE program is installed from the USB memory stick delivered with the CS4, CS4+ or CS8 stimulator. Connect the memory stick to the computer and go to the MyoPULSE folder and start the MyoPULSE Installer v1.x.x.x program (the x's is replaced by the actual version number released at the time of purchase).

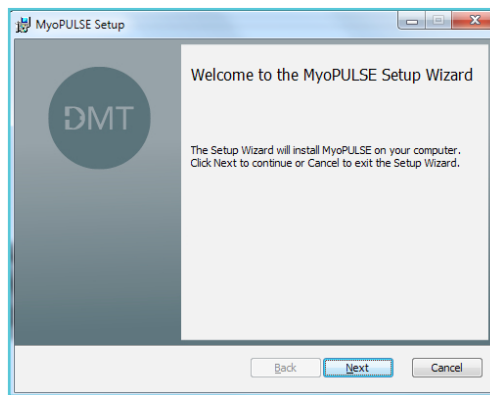

Figure B.1

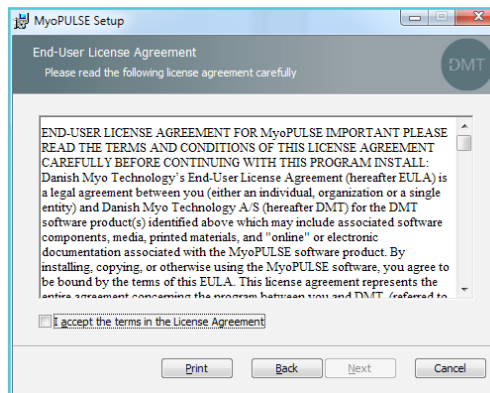

Figure B.2

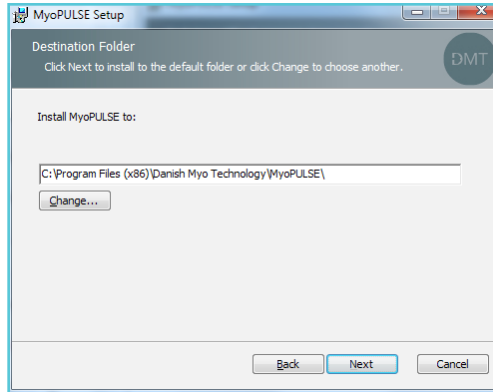

Figure B.3

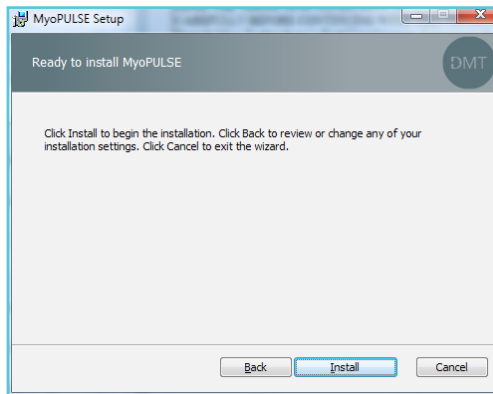

Figure B.4

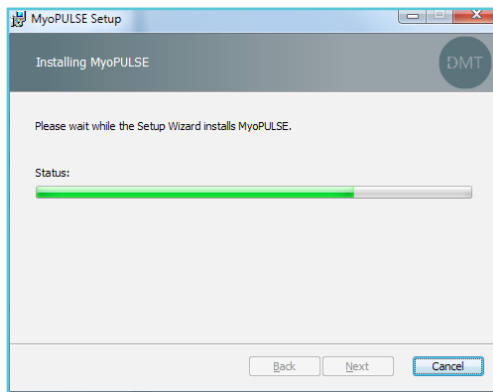

Figure B.5

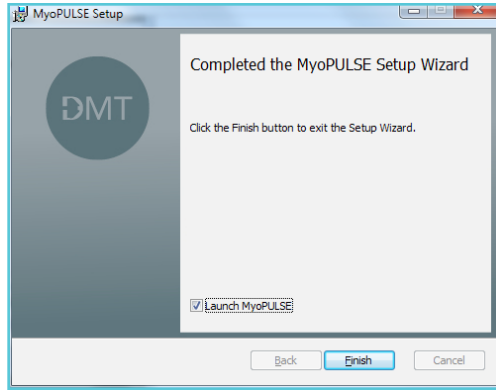

Figure B.6

APPENDIX C

TRIGGER INPUT

Pulse Trigger Input: +5V to +24V (unit protected from damage for input signals to +30 volts)

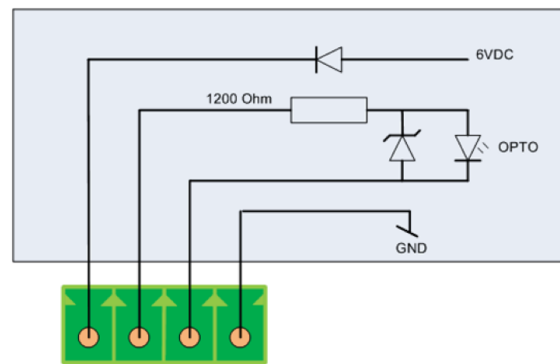

Figure C.1 INPUT connector, rear panel

Trigger Output

Pulse Trigger Output: Transistor open collector max +24 volts (unit protected from damage for signals to +30 volts).

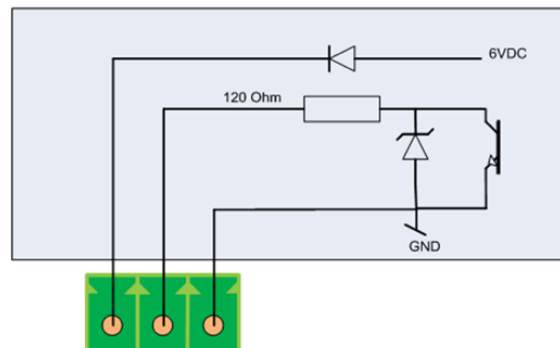

Figure C.2 OUTPUT connector, rear panel

APPENDIX D

MyoPULSE upgrades are free within the same version number. Eg. If version 2.0.0 has been purchased all upgrades up to version 2.9.9 will be free of charge. When DMT releases a new version number a complete new installation of the MyoPULSE version will be performed. In MyoPULSE, in the right corner, a question mark icon is shown. Clicking this icon will open the About MyoPULSE as seen in figure D.1. Here the license version installed can be seen. The license can either be upgraded or changed.

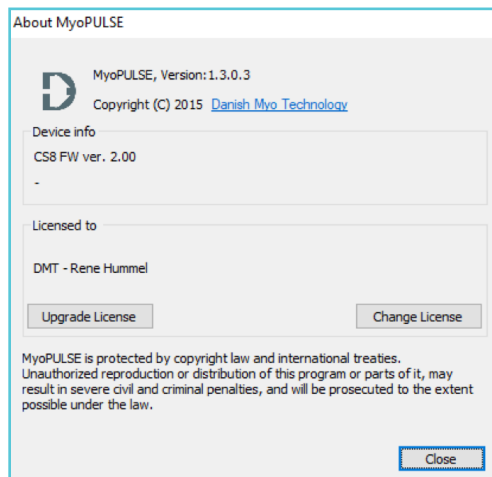

Figure D.1 License upgrade or change window.

When the Upgrade License is pressed the Customer Name and License has to be entered and then press Upgrade license (See figure D.1 and D.2).

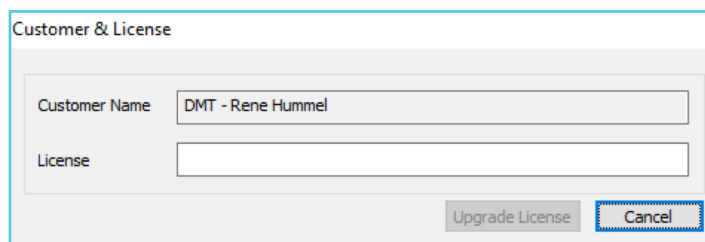

Figure D.2 Upgrade License window

When the Change License is pressed the Customer Name and License has to be entered and then press Change license (figure D3).

The image shows a dialog box titled "Customer & License". It has two input fields. The first is labeled "Customer Name" and contains the text "DMT - Rene Hummel". The second is labeled "License" and contains the text "xxxx-xxxxx-xxxxxx-xxxxxx-xxxxxx". At the bottom right of the dialog box, there are two buttons: "Change License" and "Cancel". The "Change License" button is highlighted with a blue dashed border.

Figure D.3 Upgrade License window

